

mastip[™]
hot runner solutions

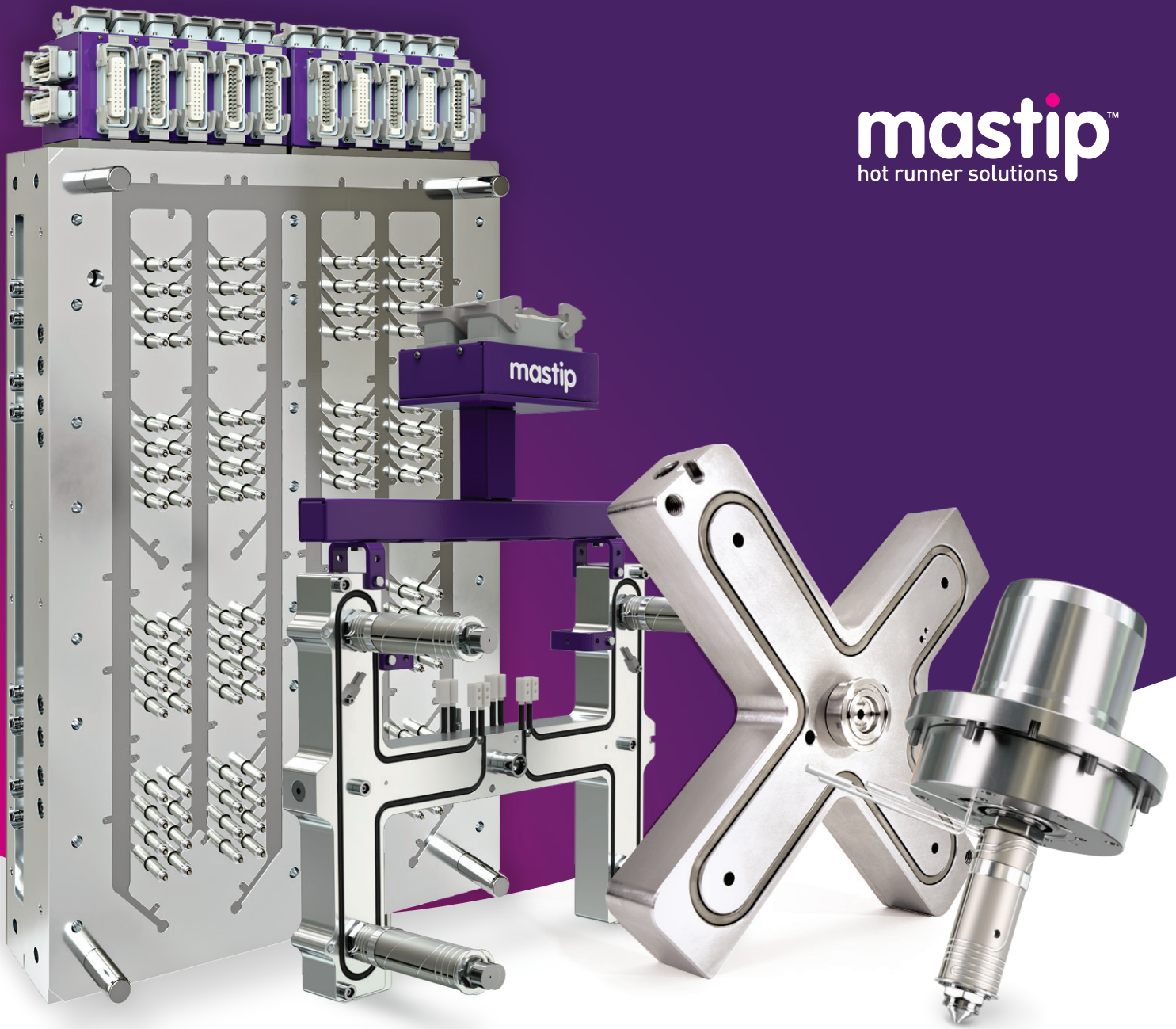







System Selection Guide

Your Complete Hot Runner
Configuration Guide

Contents	pg
Standard Hot Runner Configuration	4
Hot Runner System Overview	5
Selection Overview	6
Nozzle Range and Series Options	8
Body Grade Selection	10
Nozzle Range Selection	11
Nozzle Series Selection	12
Typical Flow Length Ratios	13
Nozzle Flow Rates	13
Tip Grade Selection	14
Tip Style Selection	15
Tip Styles	16
Nut Grade Selection	17
Nut Type Selection	18
Nut Options	19
Nozzle Assembly Order Code for X-Range Series	20
Tip and Nut Options	21
Plastic Material and Tip and Nut Suitability	22
Gate Geometry Selection	23
Gating Options – MX / BX / SX / TX FlowLoc™	24
Gating Options - YCN/Multi-Gates	25
YCN Nut	26
Multi-Gates	28
MX Nozzle	30
BX Nozzle	32
SX Nozzle	34
FlowLoc™ Range	36
VeriShot™ Single Valve Gate System	38
MVG25 Headed Pin Valve Gate System	40
MVG40 Headed Pin Valve Gate System	42
MVG40 Threaded Pin Valve Gate System	44
MVG55 Headed Pin Valve Gate System	46
Cylix Hybrid Valve Gate System	48
Manifold Components	50
Selecting a Manifold Configuration	51
Nexus™ Systems	52
Hot Half System	53
Additional Considerations	54
System Selection Example	56
Meticom CTI Touch-Screen Temperature Control System	57
Meticom CM Modular Temperature Control System	58
Meticom CIS Integrated Temperature Control System	59
Meticom SC2/SC8 Sequential Temperature Control System	60

Standard Hot Runner Configuration

KEY	
	Valve Gate Assembly
	Manifold Assembly
	Nozzle Assembly

KEY	
	Back Plate**
	Manifold Plate**
	Cavity Plate*

*Supplied by Customer

**Supplied by Mastip when hot half ordered

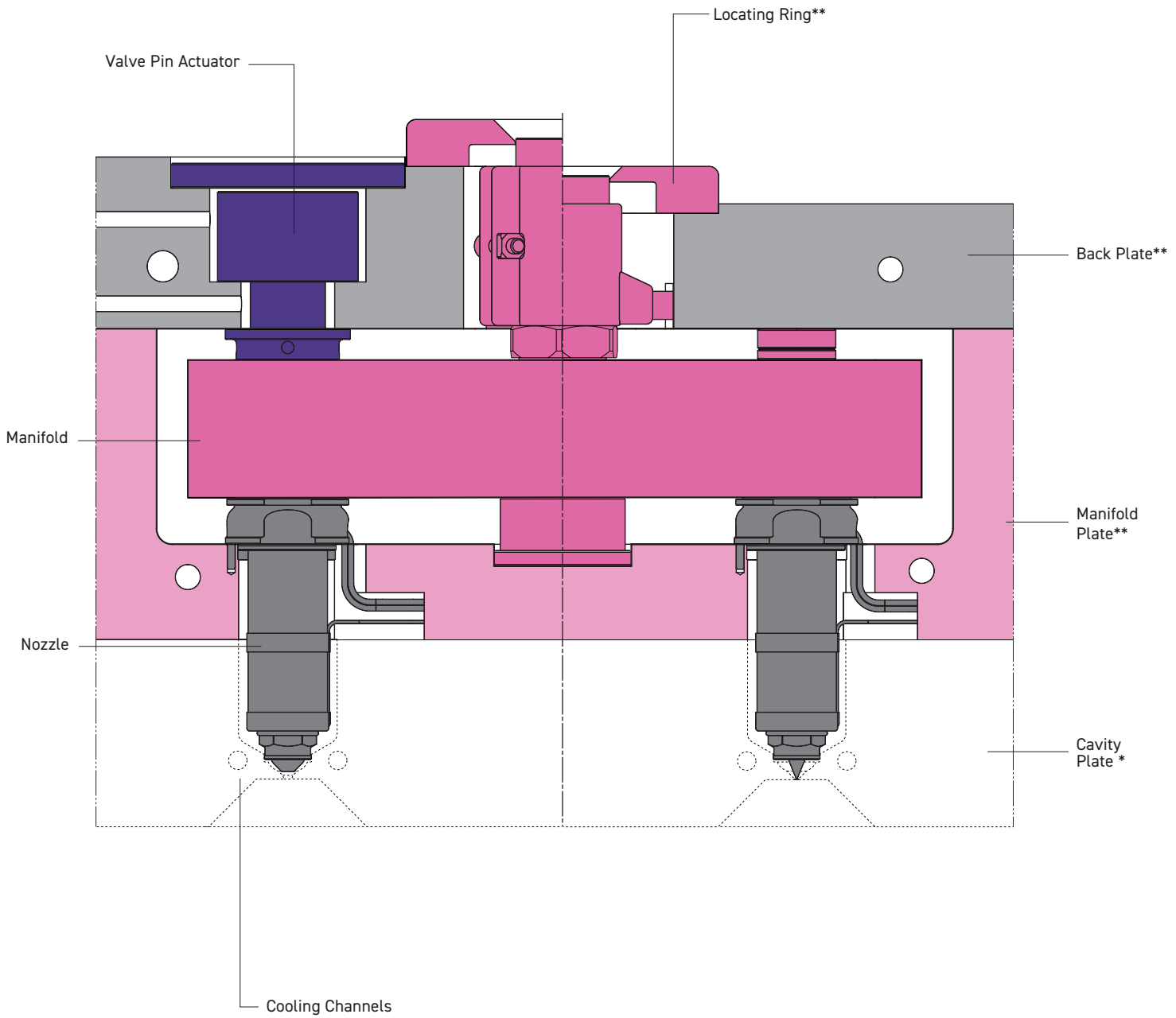

Hot Runner System Overview

A Hot Runner System maintains a molten flow of plastic from the moulding machine nozzle to the gate of a plastic injection mould.

Mastip Hot Runner System Benefits

- Efficient cycle times
- Improves part consistency and quality
- Minimised gate vestige
- Reduced injection pressure
- Valve gates allow for sequential filling and allow family part moulds
- Eliminates the cold runner that would be scrap or require re-grind
- Increased process control for fine tuning of mould and part

Hot Runner System Critical Areas of Performance

Manifold design considerations:

- Precise temperature control of the molten plastic
- Balanced flow to all cavities for even part filling
- Nozzle sizing for maintaining sufficient molten material flow
- Gate detail required to correctly fill the part and shut the gate
- No material traps or areas of flow hesitation to ensure quick colour change and prevent material degradation
- Minimum pressure drop across the Hot Runner System
- Reasonable melt residence time
- Maximum cooling of gate areas to ensure effective shut off to gates

Fully Hot Versus Semi Hot Configuration

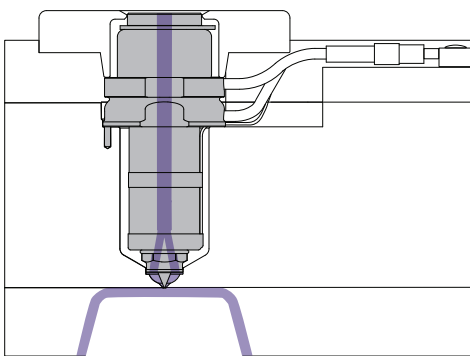

Single Nozzle Gating Directly onto Part

Fully Hot advantages:

- No material wastage
- Low cycle times
- Low part stress

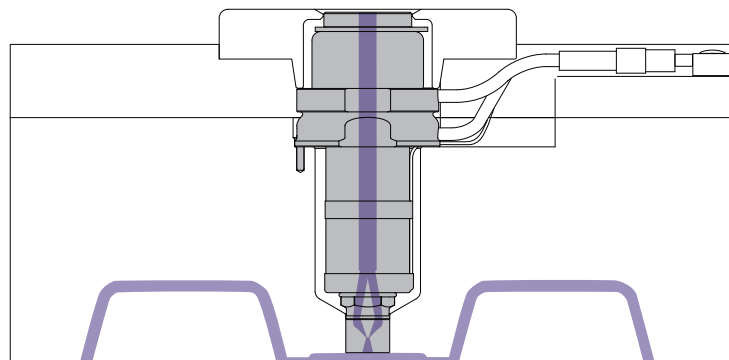

Single Nozzle Gating into a Cold Runner

Semi Hot advantages:

- Reduces cold runner weight
- Reduces cost of mould
- Suitable for difficult gate locations

Selection Overview

The easiest way to select the correct hot runner system is to follow the ten steps below.

ONE Fill in part and material details for later reference

Part Specification	Value	Unit
Part Description		
Part Weight		g
Cold runner weight (if applicable)		g
Overall size of part L x W x H		mm
Nominal Wall Thickness		mm
Minimum Wall Thickness		mm

Gate Requirements	Value
Cosmetic?	Y / N
Flat or recessed gate for label / printing?	Y / N

Mould Specifications	Value
Number of Cavities?	
Hot Half Construction?	Y / N

Material Specifications	Value
Material Type	
Filler or Glass Fibre %	
Manufacturer and grade OR MFI - Value, Temperature & load	

TWO

Using the flow chart "Body Grade Selection" on page 10 select the required nozzle body steel grade.

Body Grade	F1 / F3
------------	---------

THREE

Using the flow chart "Nozzle Range Selection" on page 11 select the required Nozzle Range.

Nozzle Range	MX / SX / BX / TX / BM / SM
--------------	-----------------------------

FOUR

Using the flow chart "Nozzle Series Selection" on page 12 and the associated tables on page 13 select the appropriate nozzle series.

Nozzle Series	09 / 13 / 16 / 19 / 27
---------------	------------------------

FIVE

Using the flow chart "Tip Grade Selection" on page 14 and the associated table select the appropriate tip grade.

Tip Grade	G1 / G2 / G5
-----------	--------------

SIX

Using the flow chart "Tip Style Selection" on page 15 and the associated table on page 16 select the appropriate tip style. For "Multi-Gate Selection" refer to page 28.

Thermal Gate	
Tip Style	TT / IT / OT
Tip Extension (optional)	+5 / +10
Multi-Gate	
Tip Style	2A/3A/4A/1S/2S/3S/4S
Valve Gate	
Tip Style	TV / OV / GV
Cap Insulator (optional)	+C

SIX CONT.

Using the flow chart "Tip Style Selection" on page 15 and the associated table on page 16 select the appropriate tip style. For "Multi-Gate Selection" refer to page 28.

Tipless Nut	
Tip Style	Y (No Tip)

SEVEN

Using the flow chart "Nut Grade Selection" on page 17 and the associated table select the appropriate nut grade.

Nut Grade	H1 / H2 / H3 / H5
-----------	-------------------

EIGHT

Using the flow chart "Nut Type Selection" on page 18 and the associated tables on page 19 select the appropriate nut style.

Thermal Gate	
Nut Style	ONT / BN / BE / SN / SX / SL / RN / RSN / YCN
Valve Gate	
Nut Style	ONT / V1B / V2B / V1S

NINE

Using the flow chart "Gate Geometry Selection" on page 23 select the appropriate gate geometry.

	units
Gate Diameter (mm)	mm
Gate Land (0.2mm max)	mm





TEN

Based on the number of cavities and/or the injection points required per part specify your manifold by attaching a drawing showing the required positions or using the L & R references as per the manifold section of the Technical Guide.

Number of nozzles on manifold	
-------------------------------	--



Nozzle Range and Series Options

Key	Suitability
✓	Available / Suitable
⊙	Application dependant
✗	Not available / Not suitable

Nozzle Range			Nozzle Series					Valve Gate	Front Loading	Single Nozzle
			09	13	16	19	27			
MX		Front loading heater for Hot Half use Close cavity pitching	✓	✓	✓	✓	✗	✓	✓	✗
BX		Cost effective solution Special length nozzles available Robust heater design Limited single nozzle use	✗	✓	✓	✓	✓	✓	✗	⊙
SX		Dedicated single nozzle solution Two heaters for optimum control	✗	✓	✓	✓	✓	✗	✗	✓
TX		Heat conducting sleeves with embedded heaters Threaded base for leak-proof operation	✗	✗	✓	✓	✓	✓	✗	✗

Nozzle Range and Series Options

Key	Suitability
✓	Available / Suitable
⊙	Application dependant
✗	Not available / Not suitable

Nozzle Range			Nozzle Series					Valve Gate	Front Loading	Single Nozzle
			09	13	16	19	27			
BM		Multi-Gates manifold range Close cavity pitching Economical and robust coil heater	✗	✗	✗	✗	✓	✗	✗	✗
SM		Multi-Gates single nozzle range Two heaters for maximum temperature control Wide moulding window	✗	✗	✗	✗	✓	✗	✗	✓

Body Grade Selection

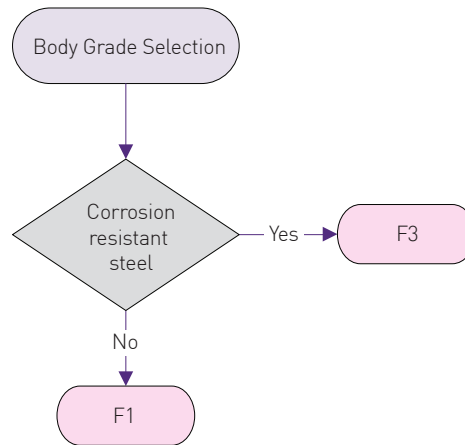

Bodies are manufactured in various grades designed for different applications and wear resistance.

Body Grade	Steel Type
F1	H13 Steel
F3	420 Corrosion Resistant Steel

Nozzle Range	F1	F3*
MX	✓	✓
BX	✓	✓
SX	✓	✓
TX	✗	✓
BM	✓	✓
SM	✓	✓

Note
 * MX09 is not available in F3

Nozzle Range Selection

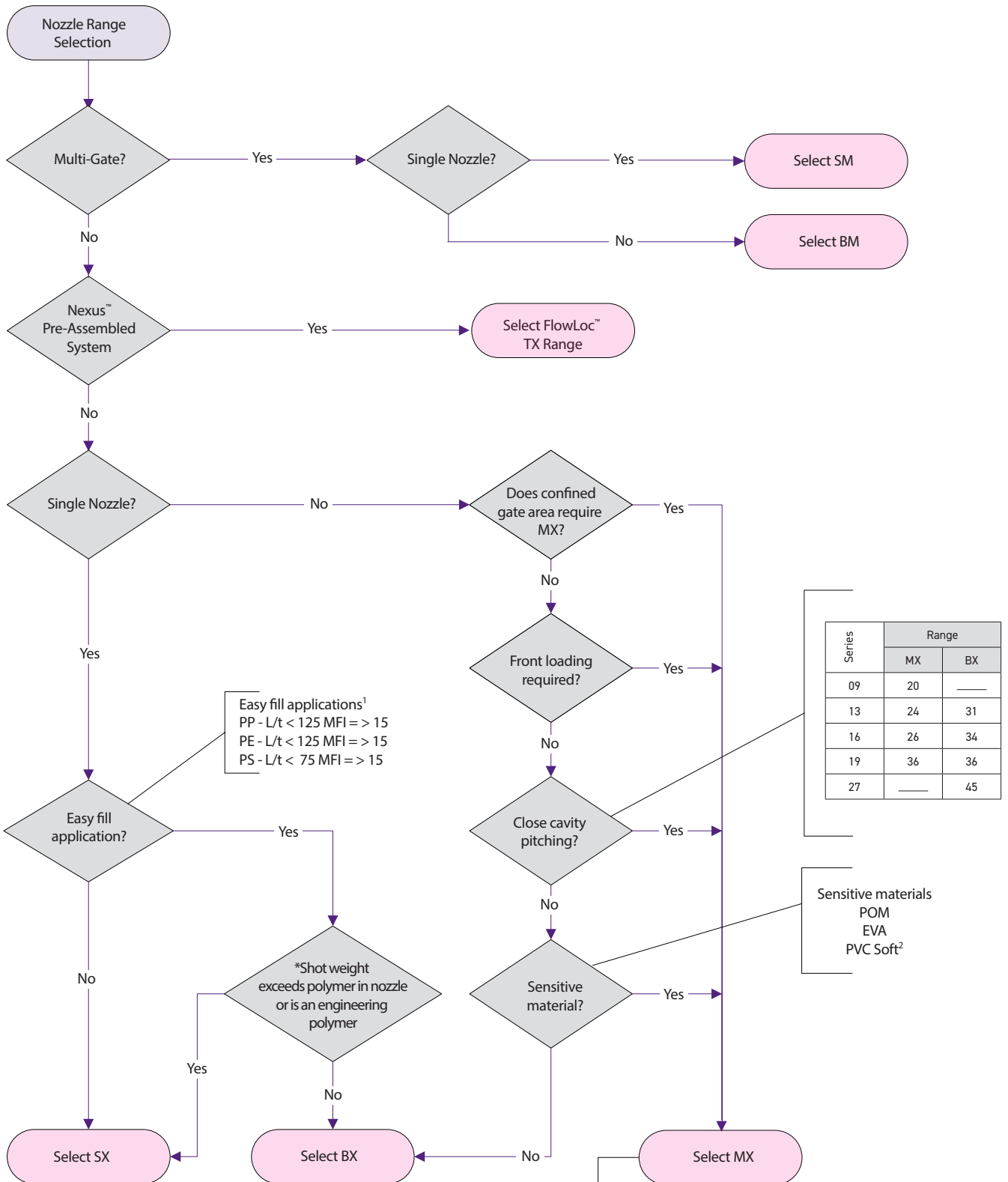

Notes

1. These examples are for typical applications only
2. Rigid PVC is not recommended for X Range

* To calculate average mass of polymer in nozzle:
Nozzle flow bore diameter x nozzle length x density

Nozzle Series Selection

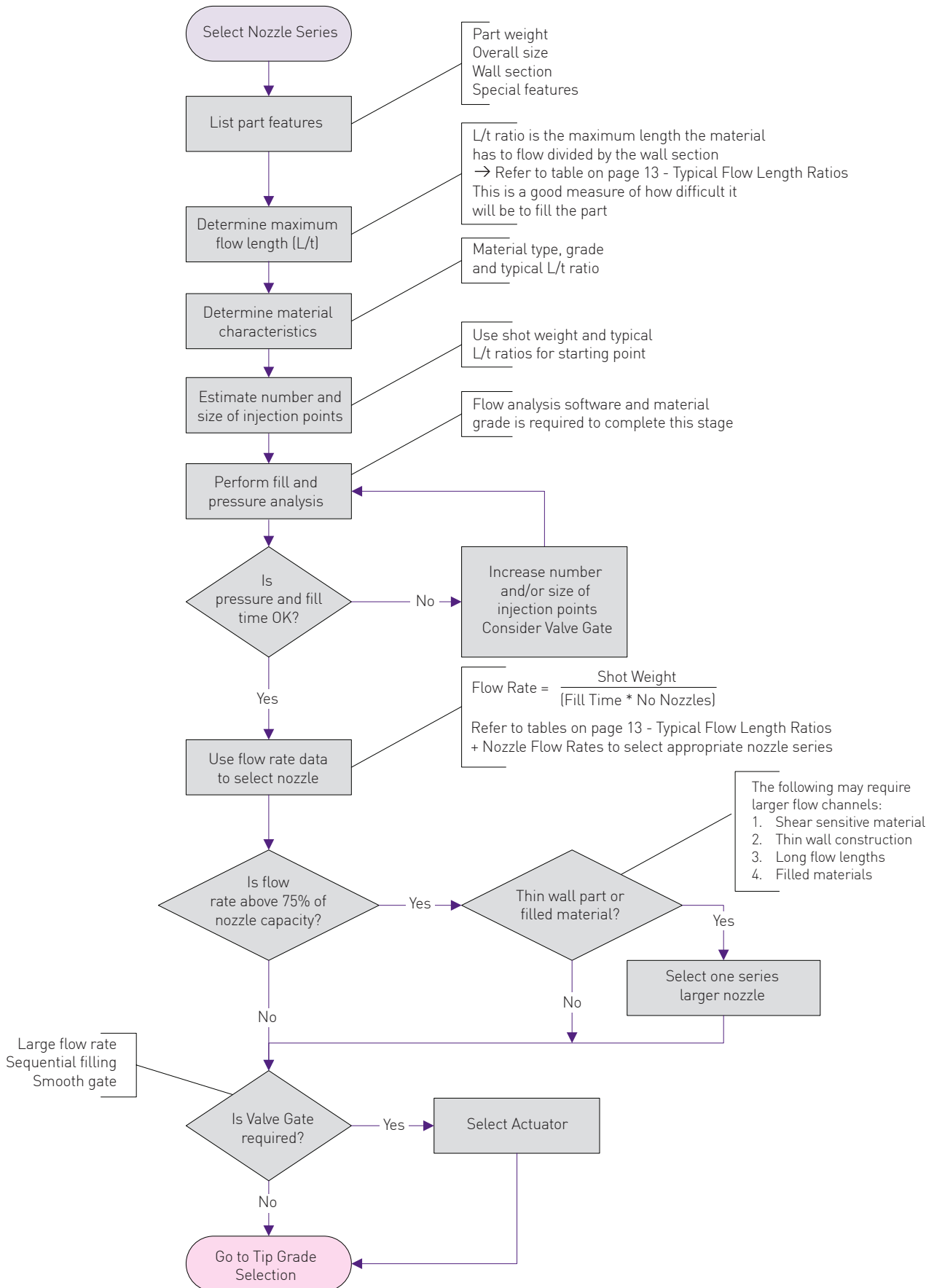

Typical Flow Length Ratios (L/t)

Material	Wall Section							
	2.0	1.5	1.0	0.8	0.7	0.6	0.5	0.4
ABS	170	96	43	27	21	15	11	7
CA	150	84	38	24	18	14	9	6
EVA	175	98	44	28	21	16	11	7
SAN	120	68	30	19	15	11	8	5
PA	150	84	38	24	18	14	9	6
PC	100	56	25	16	12	9	6	4
HDPE	225	127	56	36	28	20	14	9
LDPE	275	155	69	44	34	25	17	11
PMMA	130	73	33	21	16	12	8	5
POM	150	84	38	24	18	14	9	6
PP	250	141	63	40	31	23	16	10
UPVC	100	56	25	16	12	9	6	4

All flow lengths greater than this must be considered thin wall and the nozzle series selected accordingly.

Nozzle Flow Rates

Use the table below to select the correct nozzle series based on the flow rate required and the material category. If the material is a blend material (for example Medium-Difficult or Easy-Medium) always select the higher category to ensure the part can be filled.

Nozzle Series	Material Specifications			Material Category ²		
				Easy	Medium	Difficult
09	Thermal Gate Flow Rate	g/s	¹	15	7	3
	Shot Weight	g	¹	0.5 - 15	0.5 - 10	0.5 - 5
13	Thermal Gate Flow Rate	g/s	¹	30	15	5
	Valve Gate Flow Rate	g/s	¹	25	12	—
	Shot Weight	g	¹	0.5 -45	0.5 - 30	0.5 - 15
16	Thermal Gate Flow Rate	g/s	¹	125	65	25
	Valve Gate Flow Rate	g/s	¹	95	50	20
	Shot Weight	g	¹	1 -200	1 - 125	1 - 60
19	Thermal Gate Flow Rate	g/s	¹	300	150	60
	Valve Gate Flow Rate	g/s	¹	225	110	45
	Shot Weight	g	¹	2 -625	2 - 300	2 - 150
27	Thermal Gate Flow Rate	g/s	¹	600	300	125
	Valve Gate Flow Rate	g/s	¹	420	210	90
	Shot Weight	g	¹	10 -2000	10 - 1200	10 - 800

¹ Additives, flow length and thin wall sections all reduce the effective flow rate and shot weight. To counter the reduced flow rate and shot weight select one nozzle series larger.

² Refer to table on page 22 - Plastic Material and Tip and Nut Suitability.

For Multi-Gate Flow Rates refer to page 28.

Tip Grade Selection

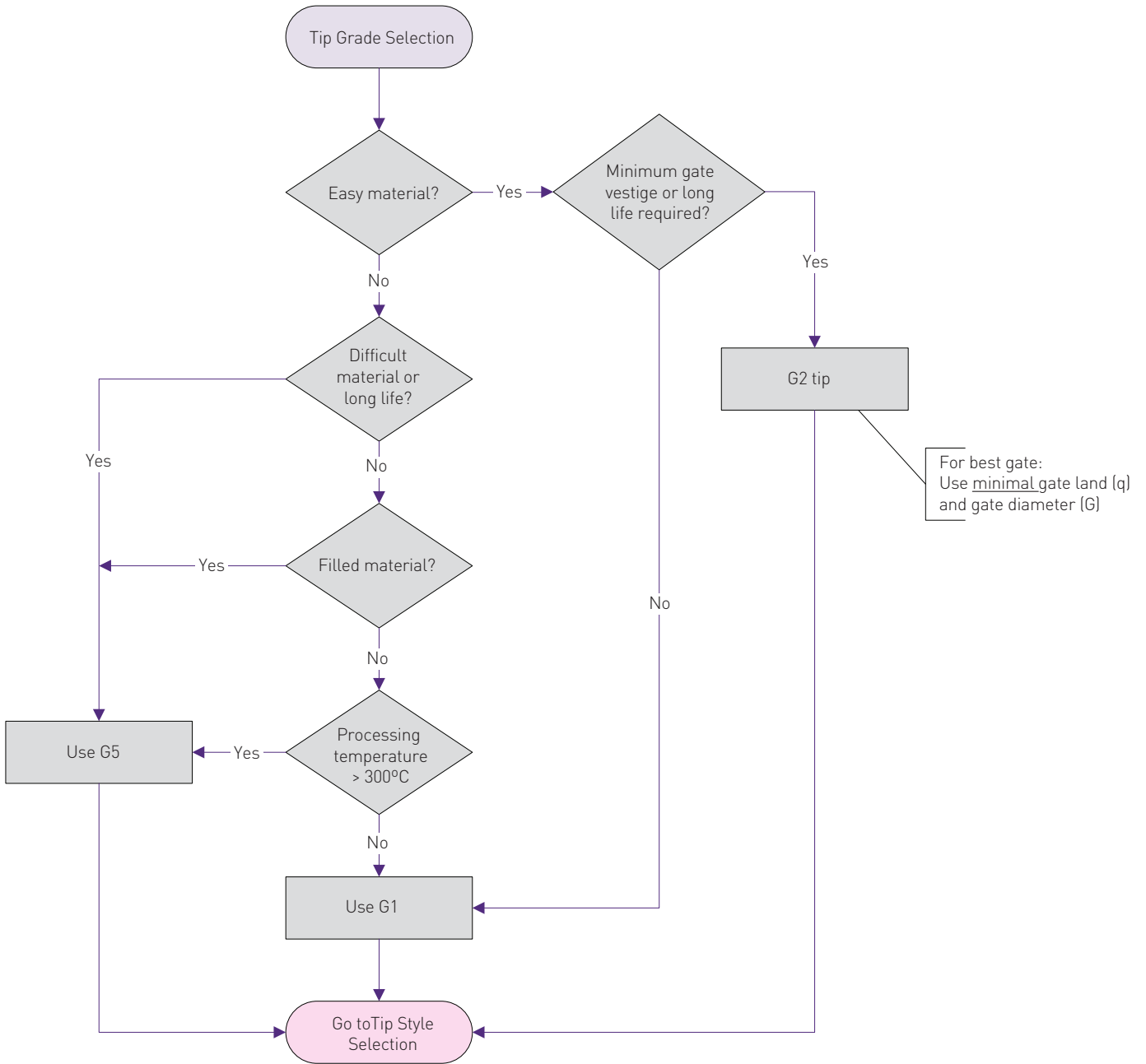

Tip Grades

Tips are manufactured in various grades designed for different applications and wear resistance.

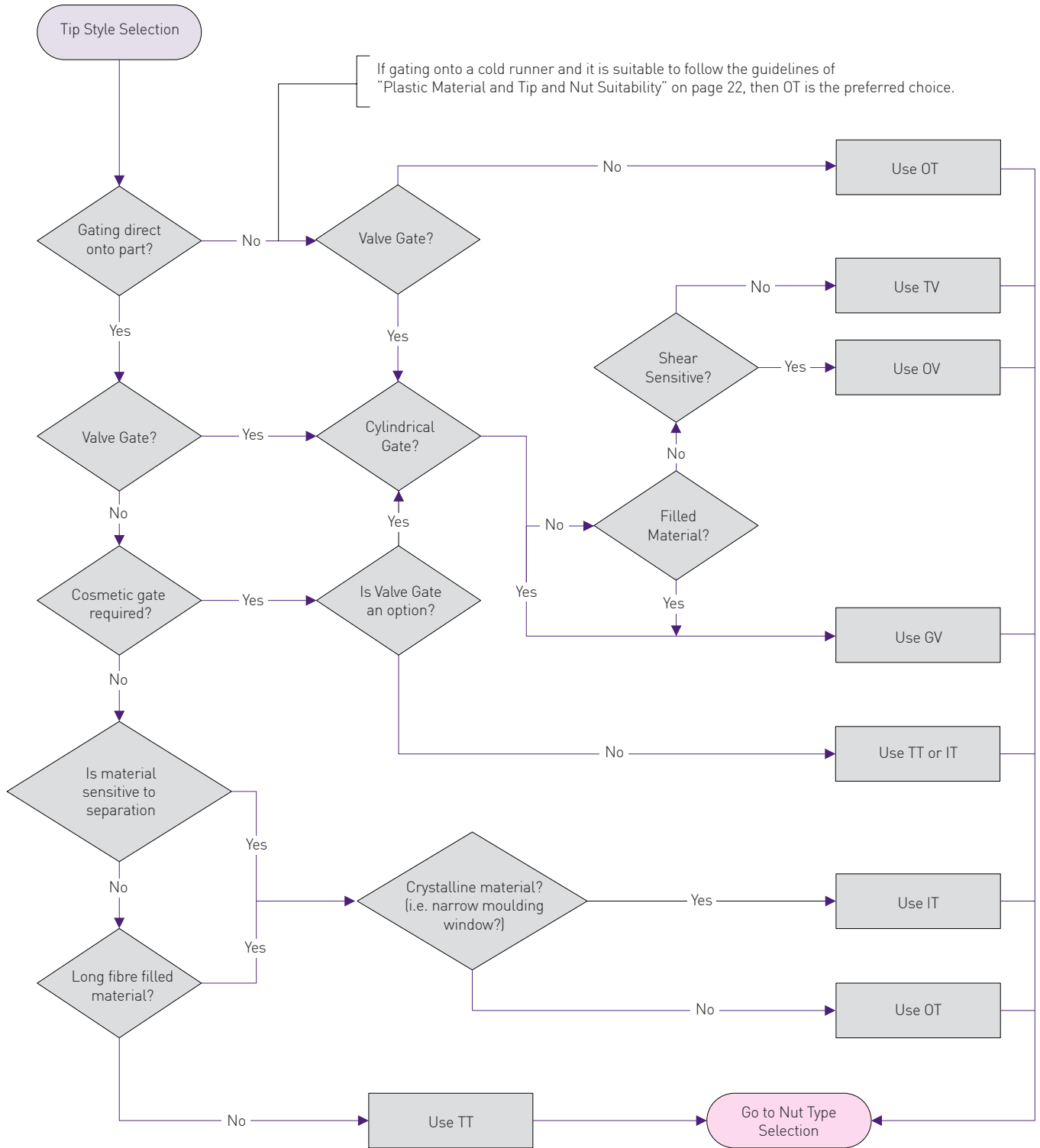

Tip Grade	Recommended use	Manufactured Material	Tip Style Options
G1	Default grade suitable for easy materials	Beryllium Copper with Nickel coating	TT, IT, OT, TV, OV
G2	Long life tip suitable for easy unfilled materials	Beryllium Copper tipped with Steel, Nickel coating	TT, IT
G5	Long life tip suitable for difficult and abrasive materials	Carbide/Hard liner	TT, IT, OT, OV, GV

Tip Style Selection

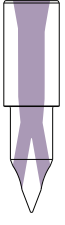
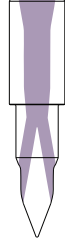
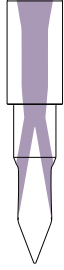
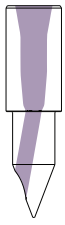
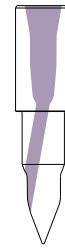

Tip Styles

Thermal Gate Tip Styles

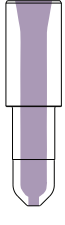
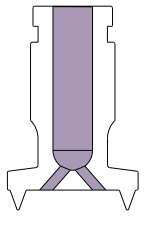
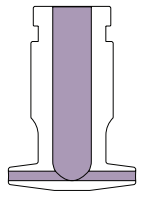
Multi Hole Torpedo Tip (TT)	Extended Torpedo Tip (TT+5)	Extended Torpedo Tip (TT+10)
		
Single Hole Torpedo Tip (IT)	Extended Single Hole Torpedo Tip (IT +5)	Extended Single Hole Torpedo Tip (IT +10)
		
Open Tip (OT)		
		
Multi-Gate Axial Tip (A)	Multi-Gate Side Tip (S)	
		

Valve Gate Tip Styles

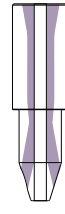
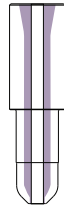
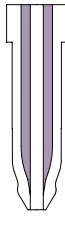
Torpedo Tip (TV)	Open Tip (OV)
	
Guided Tip (GV)	
	

Nut Grade Selection

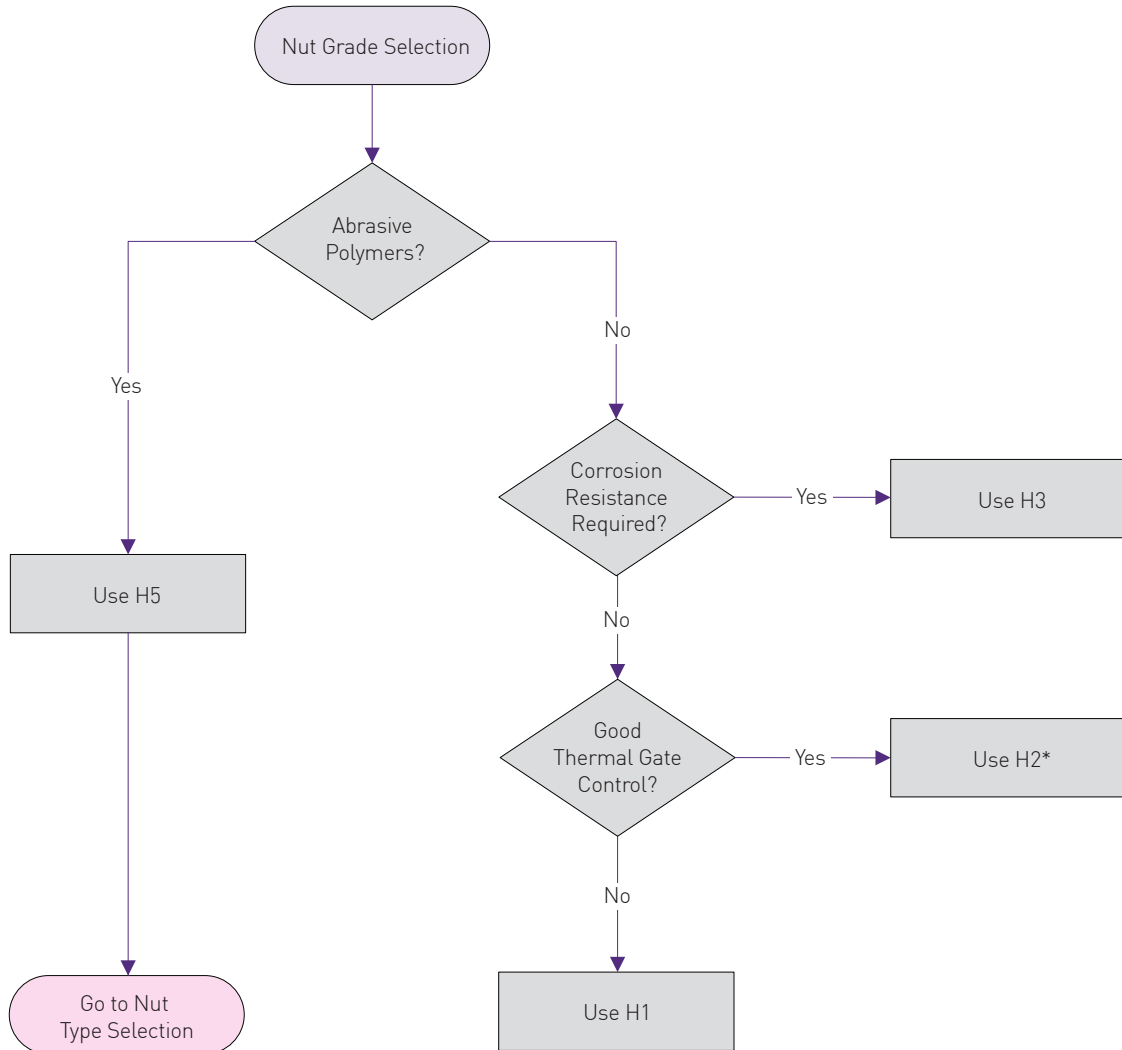

Notes

*H2 nut only available in ONT nut

Nuts are manufactured in various grades designed for different applications and wear resistance.

Nut Grade	Recommended use	Manufactured Material	Nut Style Options
H1	Default grade suitable for unfilled or lightly filled materials	H13 Steel Medium Hardness	ONT, BN, BE, SN, SL, SX, V1B, V1S
H2	Suitable for insulative properties and gate control	Titanium Low Hardness	ONT
H3	Suitable for corrosive environments	420 Corrosion Resistant Steel Medium Hardness	ONT, BN, BE, (Y)CN, SN V1B, V2B, V1S
H5	Wear resistant nut suitable for abrasive polymers	Vanadium Steel High Hardness	BN, SN, V2B

Nut Type Selection

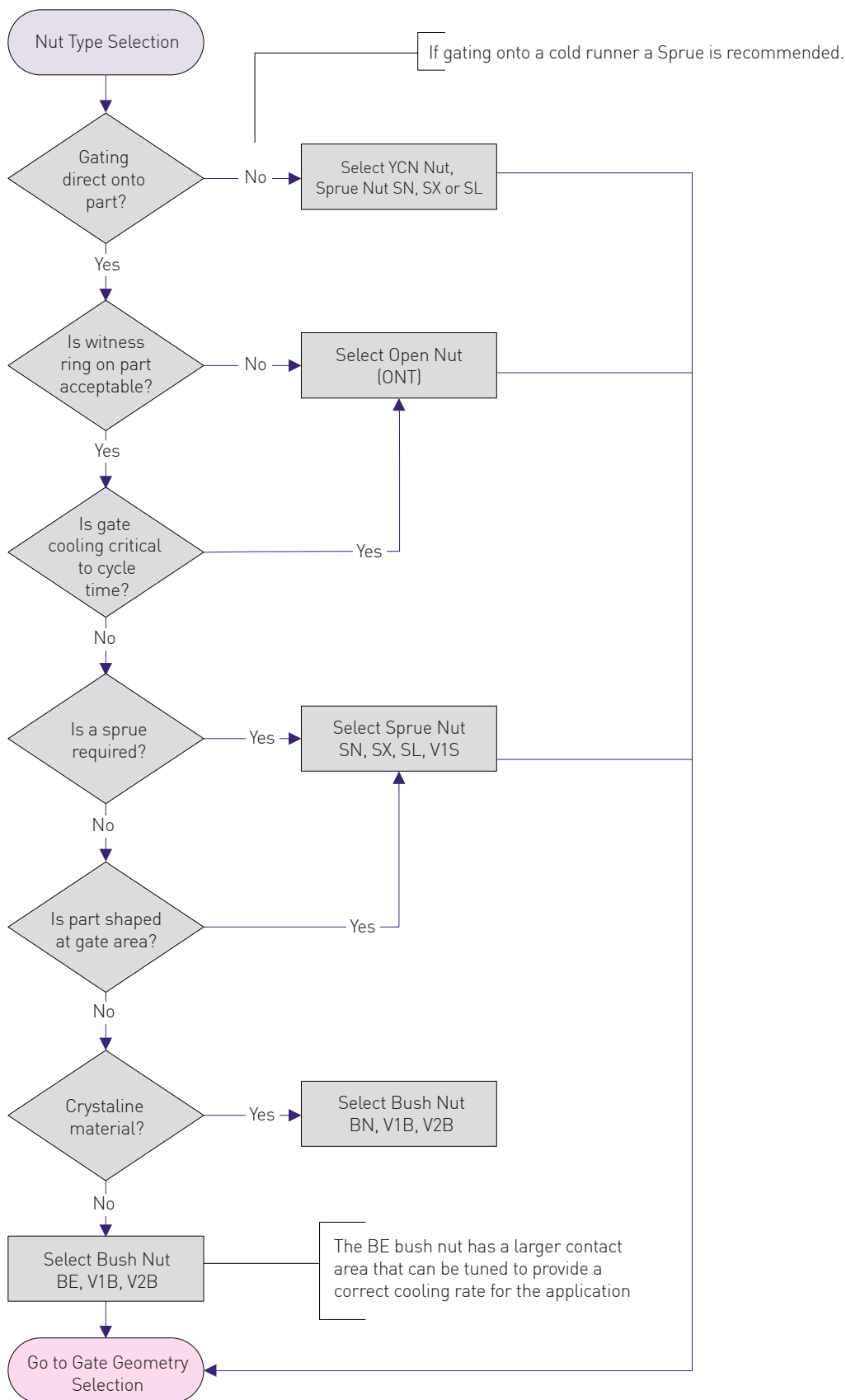

Nut Options

Key	Value
✓	Yes
✗	No
Witness	Nut will leave a circular witness mark on part
Modify	Nut may require modification to suit application

Thermal Gate Nut Types

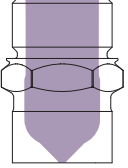
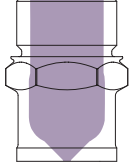
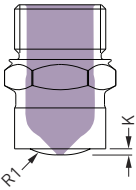
Bush Nut Full Contact (BE)		Bush Nut (BN)		Dome Nut (BD)	
Witness	✓	Witness	✓	Witness	✓
Modify	✓	Modify	✗	Modify	✓
					

For a Dome Nut supply R1 and K dimensions at time of order.

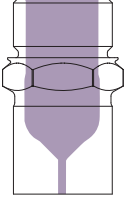
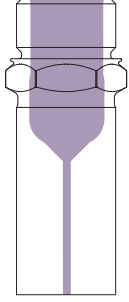
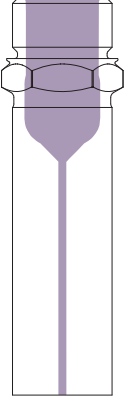
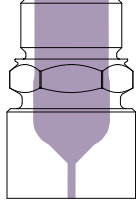
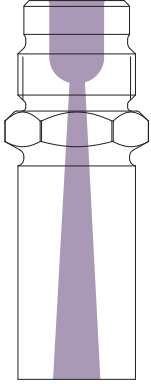
Sprue Nut +5 (SN)		Sprue Nut + 20 (SX)		Sprue Nut + 35 (SL)		Retro Sprue Nut (SN-R)		YCN Nut (YCN)	
Witness	✓	Witness	✓	Witness	✓	Witness	✓	Witness	✓
Modify	✓	Modify	✓	Modify	✓	Modify	✓	Modify	✓
									

Valve Gate Nut Types

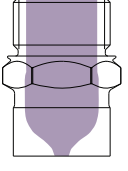
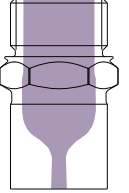
Valve Bush Nut (V1B/V2B?)		Valve Sprue Nut (V1S?)	
Witness	✓	Witness	✓
Modify	✓	Modify	✓
			

Thermal Gate and Valve Gate Nut Types

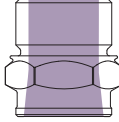
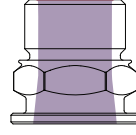
Open Nut (ONT)		Retro Nut (ONT-R)	
Witness	✗	Witness	✗
Modify	✗	Modify	✓
			

- Notes:
 1 Conical Gate
 2 Cylindrical Gate

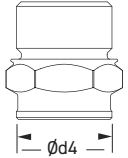
	Series	Standard Nut Ød4	Retro Nut Ød4*
	09	7	-
	13	10	13.1
	16	12	16.1
	19	15	19.1
	27	23	27.1

* Finish to suit cavity d4 -0.015mm to +/-0.005mm

Nozzle Assembly Order Code for X-Range Series

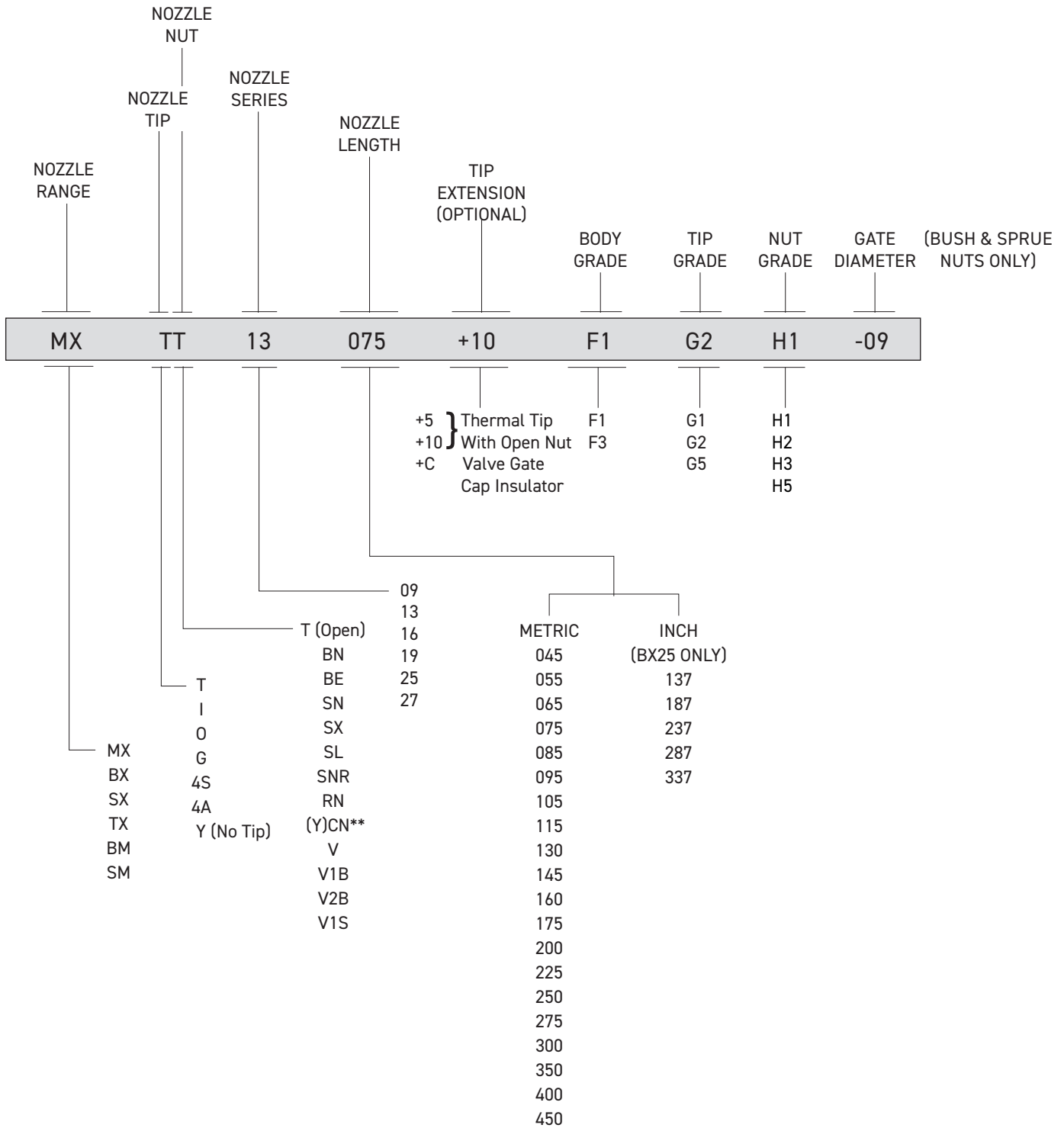



























* Multiple gate diameters are available as standard
 ** Refer to page 27 for order code diagram for YCN Nut

Tip and Nut Options

Key	Tip Suitability
✓	Available
★★★★	Highest rating
×	Not Available

- 1 Not Available in X13
- 2 Not Available in X27
- 3 Not Available in SX Series
- 4 Not Available in H5

TIPS	Grades			Nut Style			Features			Plastic (Refer to page 22)			
	G1	G2	G5	ONT	BN / BE V1B / V2B	SN/V1S SX/(Y)CN SL	Gate Quality	Flow Rate	Flow Marks	Easy	Medium	Difficult	
Thermal Gate	TT Multi Hole Torpedo Tip	✓	✓	✓				★★★	★★	★★	★★★★	★★★★	★★★
	TT+5 Extended Torpedo Tip	✓	✓	×		×	×	★★★	★★	★★	★★★★	★★	×
	TT+10 Extended Torpedo Tip	✓	✓	×		×	×	★★★	★	★★	★★★★	★	×
	IT Single Hole Torpedo Tip	✓	✓	✓				★★★	★★	★★★	★★★★	★★★★	★★★
	IT+5 Extended Torpedo Tip	✓	✓	×		×	×	★★★	★★	★★★	★★★★	★★	×
	IT+10 Extended Torpedo Tip	✓	✓	×		×	×	★★★	★	★★★	★★★★	★	×
	OT Open Tip	✓	×	✓				★★	★★★	★★★★	★★★★	★★★	★
	Y No Tip	×	×	×	×	×		★	★★★★	★★★★	★★★★	★★★★	★★★
	Multi-Gate (A) Axial Tip	✓	×	×		×	×	★★★	★★	★★	★★★★	×	×
	Multi-Gate (S) Side Tip	✓	×	×		×	×	★★	★★	★★	★★★★	×	×
Valve Gate	TV Torpedo Tip	✓	×	×				★★★★	★★★★	★★	★★★★	★★★	★
	OV Open Tip	✓	×	✓				★★★★	★★★★	★★★	★★★★	★★★	★
	GV Guided Tip	×	×	✓			×	★★★★	★★★★	★★★	★★★★	★★★	★
	YV No Tip	×	×	×	×			★★★★	★★★★	★★★	★★★★	★★★	★

Plastic Material and Tip and Nut Suitability

Key	Tip Suitability
✓	Suitable
G5	Very suitable with Grade 5 tips and H5 nuts only
⊙	Application dependant
G5	Application dependant and Grade 5 tip and H5 nuts only
✗	Not suitable

- 1** Not available in G5
- 2** Only available in G2

Material Category		Nozzle Series and Tip										
		09	13		16		19		27		A	
		TT 1 2	TT IT	OT OV	TT IT TV 1	OT OV	TT IT TV 1	OT OV	TT IT TV 1	OT OV	S	
Easy	PP	✓	✓	✓	✓	✓	✓	✓	✓	✓	✓	✓
	PE	✓	✓	✓	✓	✓	✓	✓	✓	✓	✓	✓
	PS	✓	✓	✓	✓	✓	✓	✓	✓	✓	✓	✗
	SB	✓	✓	✓	✓	✓	✓	✓	✓	✓	✓	✗
	EVA	✓	✓	✓	✓	✓	✓	✓	✓	✓	✓	✗
Medium	ABS	✓	✓	✓	✓	✓	✓	✓	✓	✓	✓	✗
	AS	✓	✓	✓	✓	✓	✓	✓	✓	✓	✓	✗
	POM	✓	✓	✓	✓	✓	✓	✓	✓	✓	✓	✗
	SAN	✓	✓	✓	✓	✓	✓	✓	✓	✓	✓	✗
	PA6	✓	✓	⊙	✓	⊙	✓	⊙	✓	⊙	✓	✗
	PMMA	✓	✓	⊙	✓	✓	✓	✓	✓	✓	✓	✗
	ASA	✓	✓	⊙	✓	✓	✓	✓	✓	✓	✓	✗
TPE	✓	✓	⊙	✓	✓	✓	✓	✓	✓	✓	✗	
Difficult	PA66	✓	✓	⊙	✓	⊙	✓	⊙	✓	⊙	✓	✗
	PBT	✗	✓	⊙	✓	⊙	✓	⊙	✓	⊙	✓	✗
	PC	⊙	✓	⊙	✓	⊙	✓	⊙	✓	⊙	✓	✗
	PPS	✗	✓	⊙	✓	⊙	✓	⊙	✓	⊙	✓	✗
	PPE	✗	✓	⊙	✓	⊙	✓	⊙	✓	⊙	✓	✗
	PSU	✗	✓	⊙	✓	⊙	✓	⊙	✓	⊙	✓	✗
	PET	⊙	✓	⊙	✓	⊙	✓	⊙	✓	⊙	✓	✗
	PES	✗	✓	⊙	✓	⊙	✓	⊙	✓	⊙	✓	✗
	PP0	✗	✓	⊙	✓	⊙	✓	⊙	✓	⊙	✓	✗
	LCP	✗	✓	⊙	✓	⊙	✓	⊙	✓	⊙	✓	✗
	PEI	✗	✓	⊙	✓	⊙	✓	⊙	✓	⊙	✓	✗
	PP + FILL	✗	G5/H5	G5/H5	G5/H5	G5/H5	G5/H5	G5/H5	G5/H5	G5/H5	G5/H5	✗
	PA + FILL	✗	G5/H5	G5/H5	G5/H5	G5/H5	G5/H5	G5/H5	G5/H5	G5/H5	G5/H5	✗
	SAN + FILL	✗	G5/H5	G5/H5	G5/H5	G5/H5	G5/H5	G5/H5	G5/H5	G5/H5	G5/H5	✗
	PA66 + FILL	✗	G5/H5	G5/H5	G5/H5	G5/H5	G5/H5	G5/H5	G5/H5	G5/H5	G5/H5	✗
	PBT + FILL	✗	G5/H5	⊙	G5/H5	⊙	G5/H5	⊙	G5/H5	⊙	G5/H5	✗
	PC + FILL	✗	G5/H5	⊙	G5/H5	⊙	G5/H5	⊙	G5/H5	⊙	G5/H5	✗
	PPS + FILL	✗	G5/H5	⊙	G5/H5	⊙	G5/H5	⊙	G5/H5	⊙	G5/H5	✗
	PPE + FILL	✗	G5/H5	⊙	G5/H5	⊙	G5/H5	⊙	G5/H5	⊙	G5/H5	✗
	PSU + FILL	✗	G5/H5	⊙	G5/H5	⊙	G5/H5	⊙	G5/H5	⊙	G5/H5	✗
PET + FILL	✗	G5/H5	⊙	G5/H5	⊙	G5/H5	⊙	G5/H5	⊙	G5/H5	✗	

Nut Grade Selection

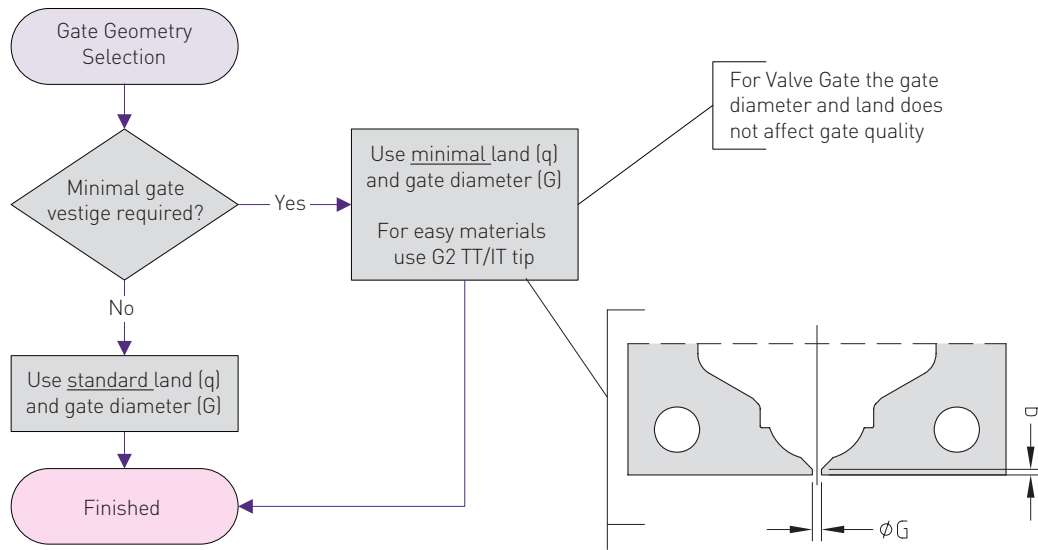

Thermal Gate Land Length (q)

Gate land ('q') Size	Cosmetic Gate	Gate Life	Other Factors
>0.20mm	Not Recommended		Increased injection pressure, premature gate freeze off
0.20mm	*	****	Recommended for materials with high % filler
0.15mm	**	***	Recommended for materials with medium % filler
0.10mm	***	**	Good balance between gate cosmetics and life
0.05mm	****	*	Strong cavity steel required. Cooled inserts required near to gate
<0.05mm	Not Recommended		Sharp edge breaks on first few shots, poor wear resistance Limited cooling at gate can result in stringing

Recommended Thermal Gate Diameter (ϕG)

Material	Tip Grade	Nozzle Series				
		09	13	16	19	27
Unfilled	G1/H1	-	0.8 - 1.3	0.9 - 1.4	1.1 - 1.6	1.8 - 2.5
	G2/H1	0.7 - 0.8	0.7 - 1.3	0.8 - 1.4	1.0 - 1.6	1.6 - 2.5
	G5/H1	-	0.9 - 1.3	1.0 - 1.4	1.2 - 1.6	2.0 - 2.5
Filled	G5/H1	-	1.0 - 1.4	1.2 - 1.5	1.5 - 1.8	2.4 - 2.8
	G5/H5	-	1.4 - 1.6	1.5 - 1.7	1.7 - 2.0	2.6 - 2.8

It is always recommended to start with a small gate and adjust as required.

Gating Options - MX/BX/SX/TX FlowLoc™

Standard Sealing Diameter					
Series	09	13	16	19	27
Ød4	7	10	12	15	23

ONT					ONT +5					ONT +10					
09	13	16	19	27	09	13	16	19	27	09	13	16	19	27	
✓	✓	✓	✓	✓	✓	✓	✓	✓	✓	×	✓	✓	✓	✓	✓
SN +5				SX +20				SL +35							
13	16	19	27	13	16	19	27	13	16	19	27				
✓	✓	✓	✓	✓	✓	✓	✓	×	✓	✓	✓	✓			
BN / BE				V1B/V2B				V1S							
13	16	19	27	13	16	19	27	13	16	19	27				
✓	✓	✓	✓	×	✓	✓	✓	×	✓	✓	✓				

Gating Options - YCN Thermal

Standard Sealing Diameter				
Series	13	16	19	27
Ød4	10	12	15	23

YCN +20				YCN +35			
13	16	19	27	13	16	19	27
✓	✓	✓	✗	✗	✗	✗	✓

Gating Options - Multi Gates

Axial Gate*				Side Gate*			
13	16	19	27	13	16	19	27
✗	✗	✗	✓	✗	✗	✗	✓

* Pocket dimensions to be supplied by Mastip

YCN Open Tipless Nut

YCN Nut is designed for X-range nozzles, providing open flow moulding. An ideal moulding solution for indirect-feed via a cold runner. Ideal for Thermal Gate applications.

YCN Nut

Features

- Internal nut profiles to suit different materials and temperature requirements
- No high-conductivity tip insert required
- Tipless nut provides open flow moulding
- Minimises melt shear
- Lowers the overall pressure drop through the gate
- Provides a broad repeatable moulding window

Applications

- Moulding applications that suit open flow injection
- Cosmetic gate is not required on moulded part
- Ideal for indirect-feed via a cold runner
- Moulding applications where a moulded sprue is acceptable
- Thermal Gate applications

Gating Options

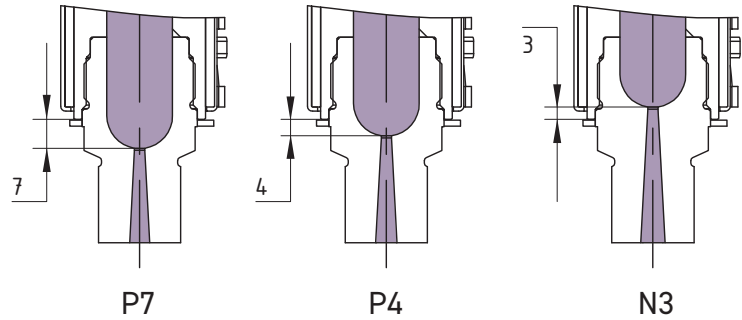

P7	Easy material/ Low temperature	Gate is located 7mm forward of the heat source	E.g. PP, PE, ABS, ASA, SAN
P4	Mid-Range	Gate is located 4mm forward of the heat source	E.g. PC, POM, PMMA PA
N3	Difficult material/ High temperature	Gate is located 3mm behind the heat source	E.g. PBT, PET, PPS PEI, PPO

YCN Nut Extension

YCN Nuts are stocked with a standard extension length

X13	X16	X19	X27
20mm	20mm	20mm	35mm

Gate Diameter

X-Range YCN Nuts are stocked with standard gate diameters according to the nozzle series, nut style and filled or unfilled material.

Unfilled	X Range – YCN Nut Style			Filled	X Range – YCN Nut Style				
	Series	P7	P4		N3	Series	P7	P4	N3
	13	Ø1.2	Ø1.3	Ø1.3		13	Ø1.6	Ø1.8	Ø1.8
	16	Ø1.4	Ø1.5	Ø1.5		16	Ø1.8	Ø2.0	Ø2.0
	19	Ø1.8	Ø2.0	Ø2.0		19	Ø2.2	Ø2.5	Ø2.5
	27	Ø2.2	Ø2.5	Ø2.5		27	Ø2.7	Ø3.0	Ø3.0

Custom gate and taper available on request.

Standard sprue taper is 6°

YCN Nut Selection

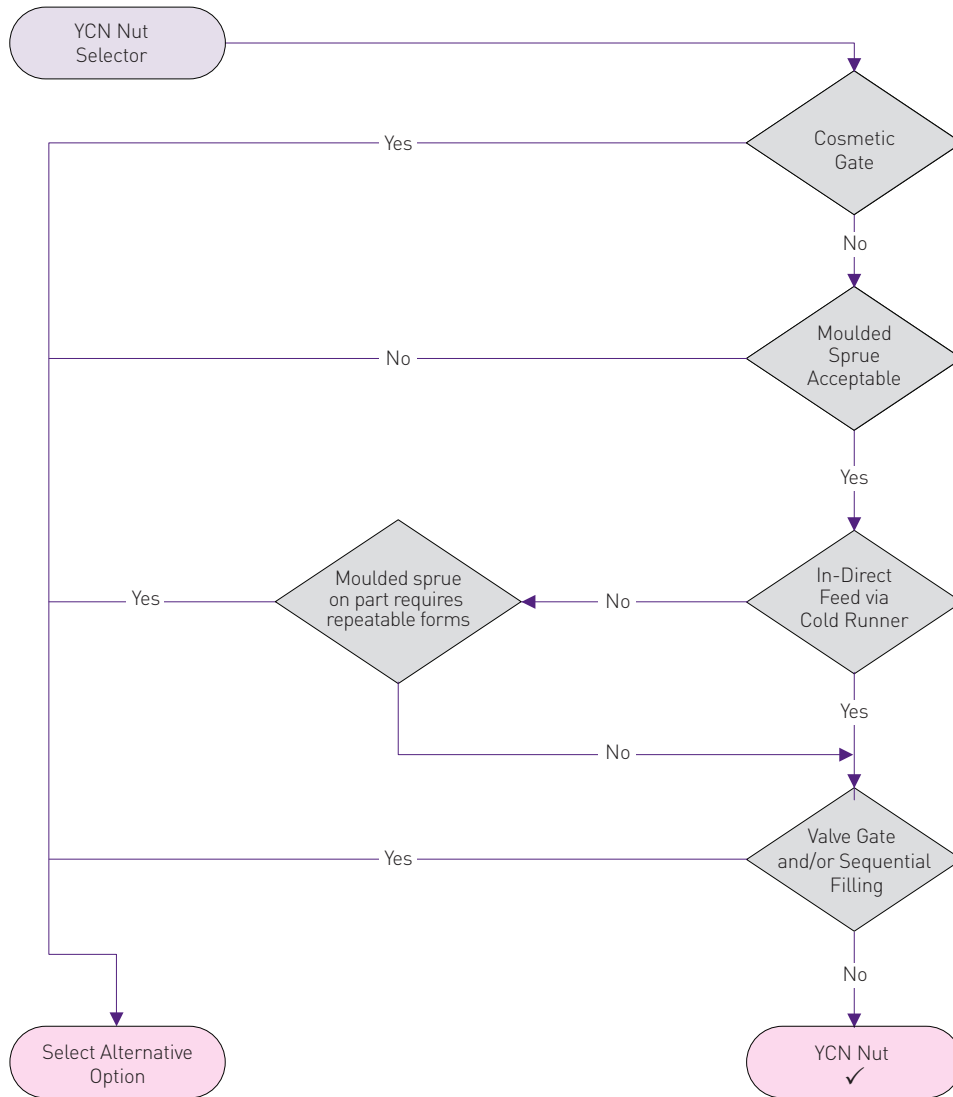

Nozzle Order Code for X-Range YCN Thermal Nut Series

NOZZLE RANGE	YCN NUT	NOZZLE SERIES	NOZZLE LENGTH	BODY GRADE	NUT GRADE	GATE PROFILE	POLYMER CLASSIFICATION	GATE DIAMETER
BX	YCN	27	175	F1	H3	P4	F	-30
MX	YCN	13	045 160	F1	H3	P7	U (Unfilled)	EXAMPLE OF A FINAL ORDER CODE
BX		16	055 175	F3		P4	F (Filled)	
SX		19	065 200			N3	SP	
TX		27	075 225					
			085 250					
			095 275					
			105 300					
			115 350					
			130 400					
			145 450					

Multi-Gates

Mastip's Multi-Gate solutions are engineered specifically for challenging applications requiring close pitch gates in restricted areas where conventional gating methods aren't possible.

Multi-Gates

Features

- Axial multi-gates allow close cavity pitching with a pitch circle diameter (PCD) from 10.00 to 22.00 with the ability to offer 2 to 4 gates per tip
- Side multi-gate allowing close cavity pitching with a gate well diameter from 22.30mm to 26.80mm with the ability to offer 1 to 4 gates per tip
- Highly conductive tip allowing for precise thermal control
- Tip flow channels designed to optimise and balance the thermal profile
- The M-Range nozzles are designed specifically for multi-gate solutions incorporating BX/SX proven technology

Applications

- Multiple part direct injection gating with one nozzle either in an Axial or Side gate tip style
- Side multi-gates allow internal side gating on single complex round parts that need a highly balanced fill
- Axial multi-gates allow for direct gating on single complex round parts that need a highly balanced fill
- Only polymers that are easy to process such as polyolefins with long residence times to be processed through the multi-gates

Gate Styles

Axial Gate

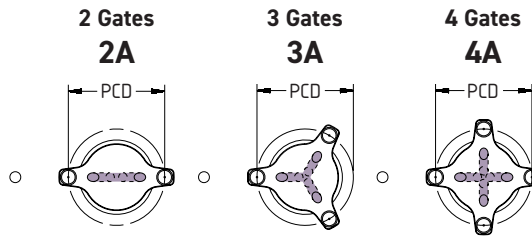

Side Gate

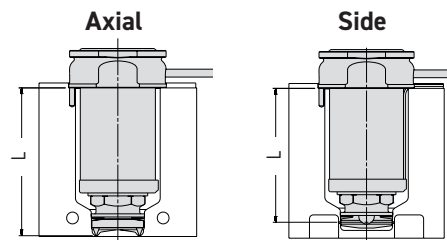
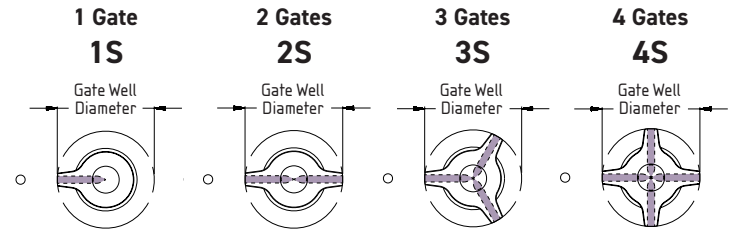

BM / SM Standard Gate Lengths

Gate	Nozzle	Series	L (Nozzle)						
Axial Gate	BM	27	75	95	115	145	175	225	275
	SM	27	75	95	115	145	175	225	275
Side Gate	BM	27	69	89	109	139	169	219	269
	SM	27	69	89	109	139	169	219	269

Multi-Gate Flow Rates

Nozzle Series	Material Specifications		Material (Polyolefn)
M27	Flow Rate	g/s/gate	15
	Shot Weight	g	0.5 - 15
	Gate Size - Axial	mm	0.7 - 1.0
	Gate Size - Side	mm	0.5 - 1.0 (max 70% part wall thickness)

Multi-Gates Selection

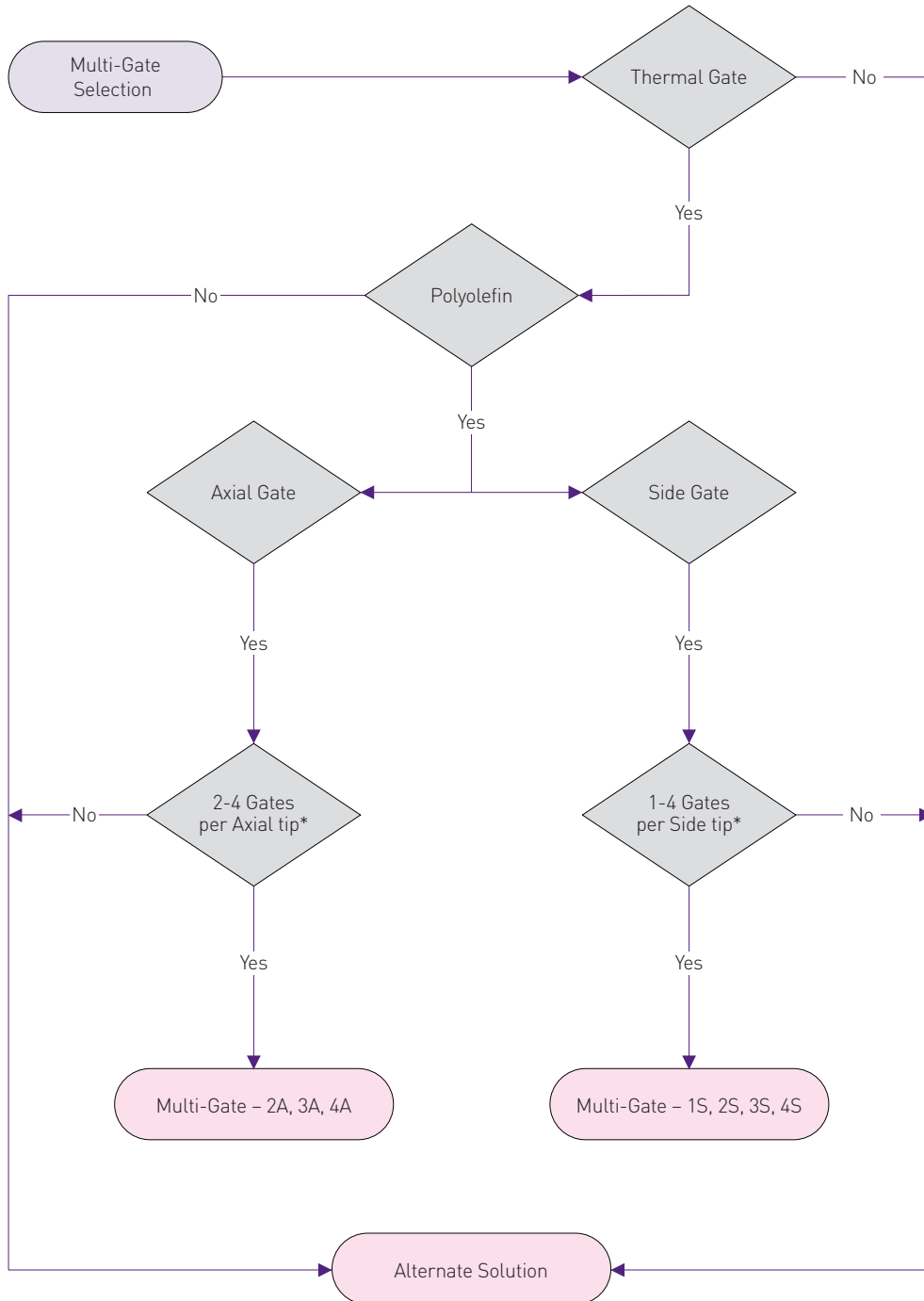

* Number of gates required not included in flow chart, contact Mastip.

MX Nozzle Overview

MX nozzle, specifically designed for multi cavity manifold systems and hot halves.

MX FEATURES

Mould design

- Efficiently designed profile to allow closer cavity pitching
- Shares the same gate profiles as BX and SX
- Available in both thermal and valve gate options
- Consistent nozzle lengths across the range
- Ability to mould large parts with smaller nozzles due to optimum flow characteristics

Operation

- Wide moulding window
- Excellent temperature profile and thermal stability
- Operates at low moulding pressure and temperature
- Optimum cycle times due to superior thermal insulation
- Uses an advanced micro coil heater with integrated heat deflection tube

Installation and maintenance

- Front loading capability for easier servicing of tips, heaters and thermocouples
- Simple machining and installation requirements
- Improved reliability due to the use of advanced materials
- Common tip and nut options provide ready availability of spare parts

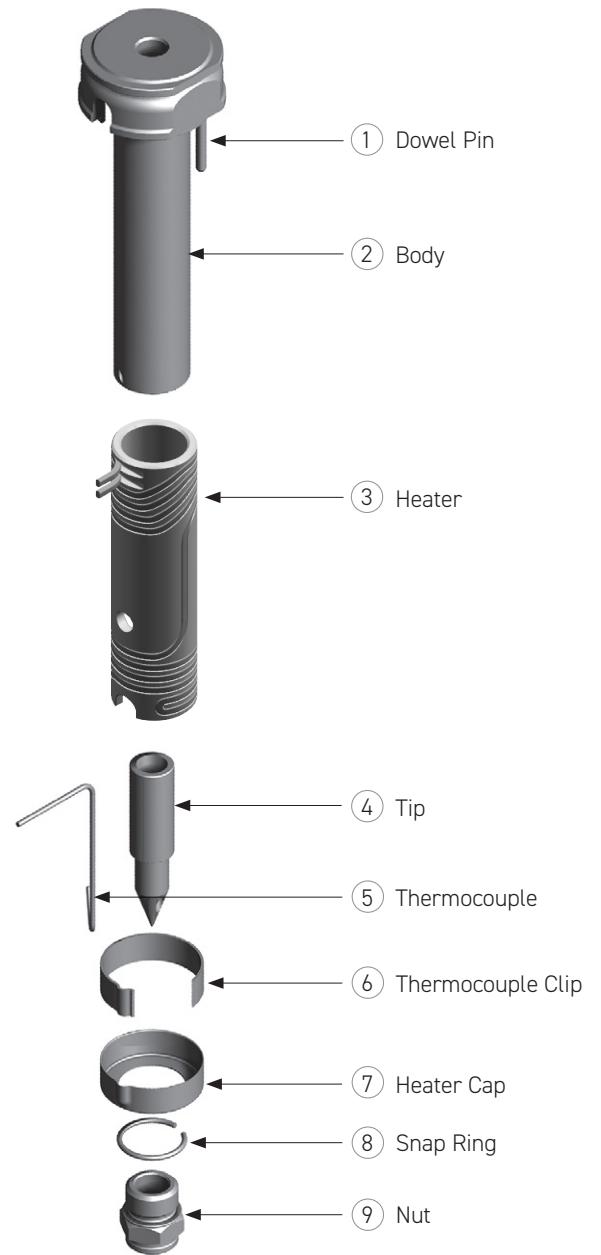

MX Nozzle Body Lengths**													
Series	Steel	45	55	65	75	85	95	105	115	130	145	160	175
09	H13 (Std)	—	F1	F1	F1	F1	F1	F1	F1	F1	F1	F1	F1
13	H13 (Std)	F1	F1	F1	F1	F1	F1	F1	F1	F1	F1	F1	F1
	420 (SS)	F3*	F3*	F3*	F3	F3	F3	F3*	F3*	F3*	F3*	F3*	F3*
16	H13 (Std)	F1	F1	F1	F1	F1	F1	F1	F1	F1	F1	F1	F1
	420 (SS)	F3*	F3*	F3	F3	F3	F3	F3	F3	F3*	F3*	F3*	F3*
19	H13 (Std)	—	F1	F1	F1	F1	F1	F1	F1	F1	F1	F1	F1
	420 (SS)	—	F3*	F3*	F3	F3	F3	F3	F3	F3*	F3*	F3*	F3*

* Length not currently stocked, available on request
 ** Custom lengths available on request, BX recommended
 Available in H13 and 420 steel

MX Nozzle Series

MX09

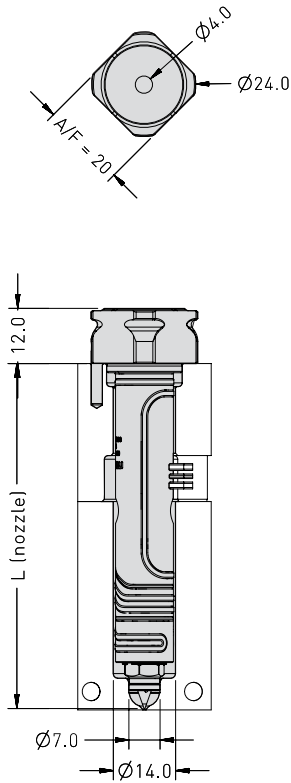

MX13

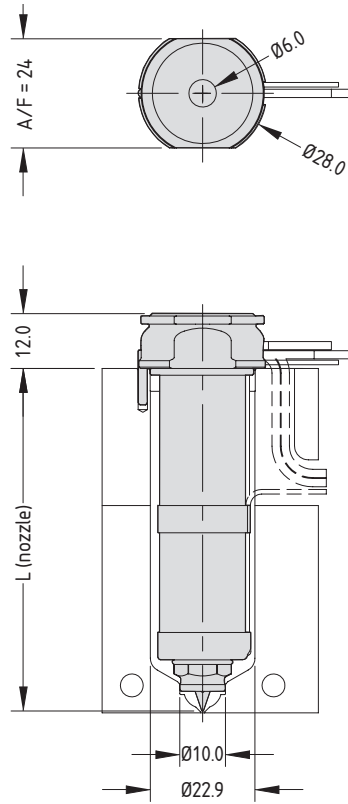

MX16

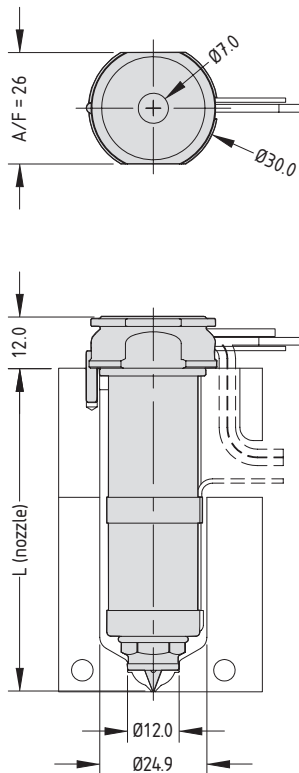

MX19

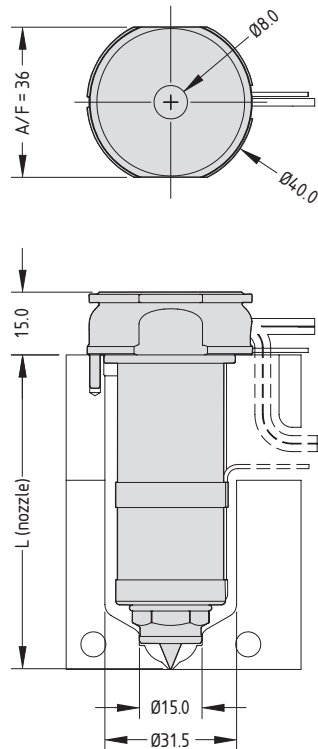

BX Nozzle Overview

BX nozzle is designed to provide cost sensitive solutions for low to medium cavitation applications, not requiring hot half construction.

BX FEATURES

Mould Design

- Ability to easily order special length nozzles
- Shares the same gate profiles as MX and SX
- Available in both thermal and valve gate options
- Consistent nozzle lengths across the range
- Ability to mould large parts with smaller nozzles due to optimum flow characteristics

Operation

- Wide moulding window
- Excellent temperature profile and thermal stability
- Operates at low moulding pressure and temperature
- Optimum cycle times due to superior thermal insulation
- Uses an economical and robust coil heater

Installation and Maintenance

- Simple machining and installation requirements
- Improved reliability due to the use of advanced materials
- Common tip and nut options provide ready availability of spare parts

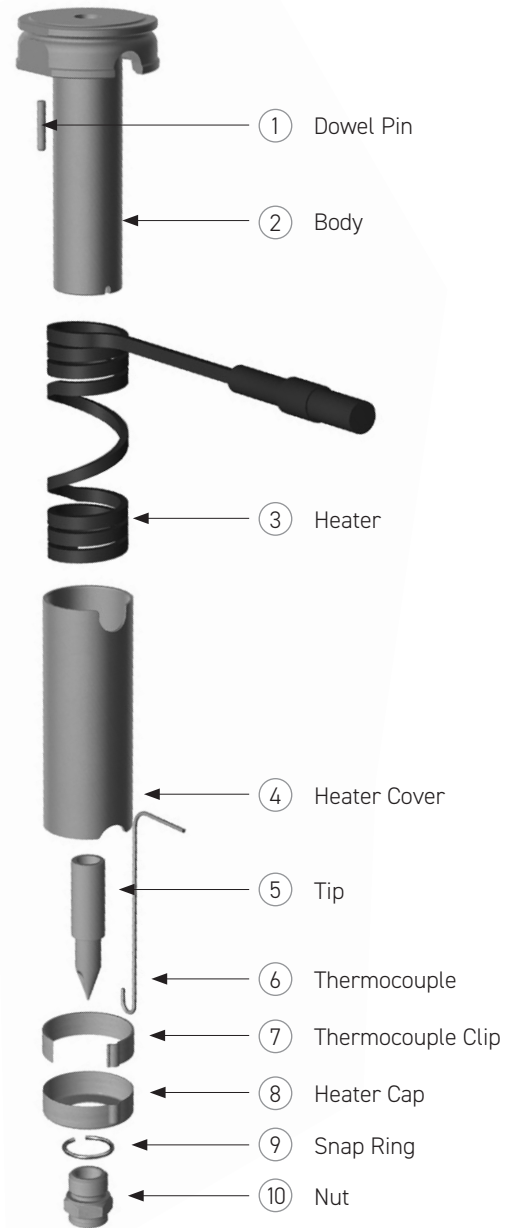

BX Nozzle Body Lengths**																					
Series	Steel	45	55	65	75	85	95	105	115	130	145	160	175	200	225	250	275	300	350	400	450
13	H13 (Std)	F1	F1	F1	F1	F1	F1	F1	F1	F1	F1	F1	F1	F1*	F1*	—	—	—	—	—	—
	420 (SS)	F3*	F3*	F3	F3	F3*	F3	F3*	F3*	F3*	F3*	F3*	F3*	F3*	F3*	—	—	—	—	—	—
16	H13 (Std)	F1	F1	F1	F1	F1	F1	F1	F1	F1	F1	F1	F1	F1*	F1*	F1*	—	—	—	—	—
	420 (SS)	F3*	F3*	F3	F3	F3*	F3	F3*	F3	F3*	F3*	F3*	F3*	F3*	F3*	F3*	—	—	—	—	—
19	H13 (Std)	F1	F1	F1	F1	F1	F1	F1	F1	F1	F1	F1	F1	F1*	F1*	F1*	F1*	F1*	—	—	—
	420 (SS)	F3*	F3*	F3*	F3	F3*	F3	F3*	F3	F3*	F3*	F3*	F3*	F3*	F3*	F3*	F3*	F3*	—	—	—
27	H13 (Std)	—	—	—	F1	F1	F1	F1	F1	F1	F1	F1	F1	F1	F1	F1	F1	F1*	F1*	F1*	F1*
	420 (SS)	—	—	—	F3	F3*	F3	F3*	F3	F3*	F3*	F3*	F3*	F3*	F3*	F3*	F3*	F3*	F3*	F3*	F3*

* Length not currently stocked, available on request

** Custom lengths available on request

Available in H13 and 420 steel

BX Nozzle Series

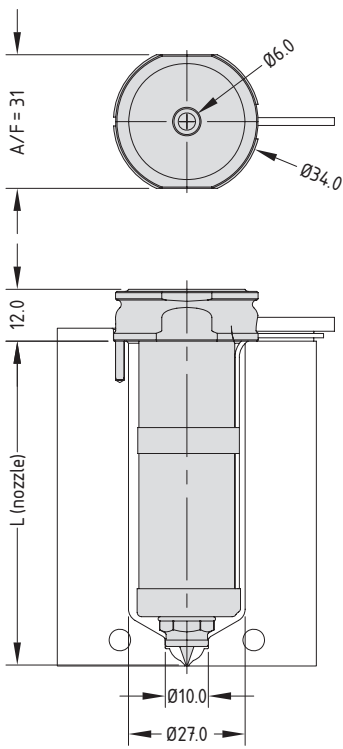

BX13

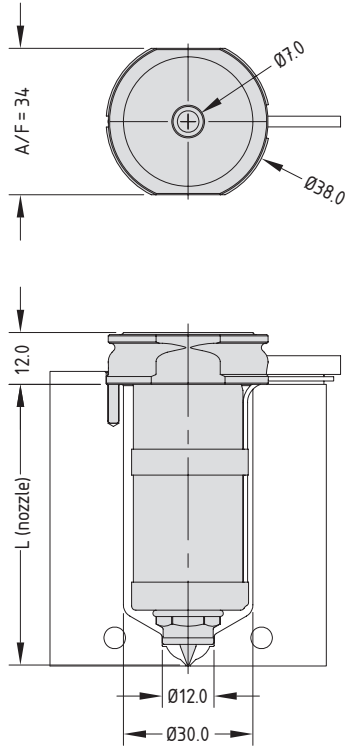

BX16

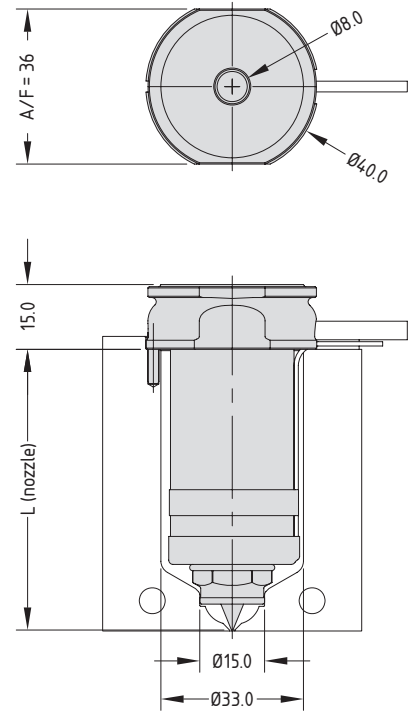

BX19

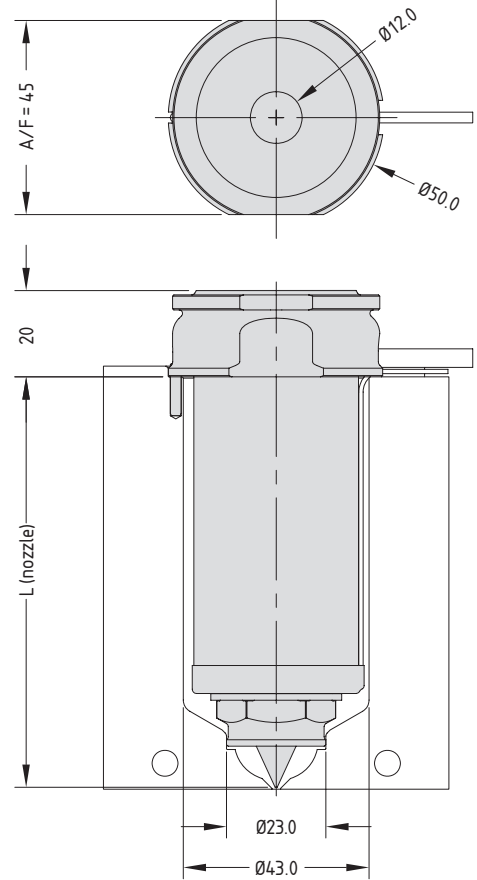

BX27

SX Nozzle Overview

With two heaters the SX nozzle is perfectly suited for all single nozzle applications.

SX FEATURES

Mould Design

- Ability to easily order special length nozzles
- Shares the same gate profiles as MX and BX
- Consistent nozzle lengths across the range
- Ability to mould large parts with smaller nozzles due to optimum flow characteristics

Operation

- Separate heater for the nozzle head for maximum temperature control
- Wide moulding window
- Excellent temperature profile and thermal stability
- Operates at low moulding pressure and temperature
- Optimum cycle times due to superior thermal insulation
- Uses economical and robust coil heaters

Installation and Maintenance

- Simple machining and installation requirements
- Improved reliability due to the use of advanced materials
- Common tip and nut options provide ready availability of spare parts

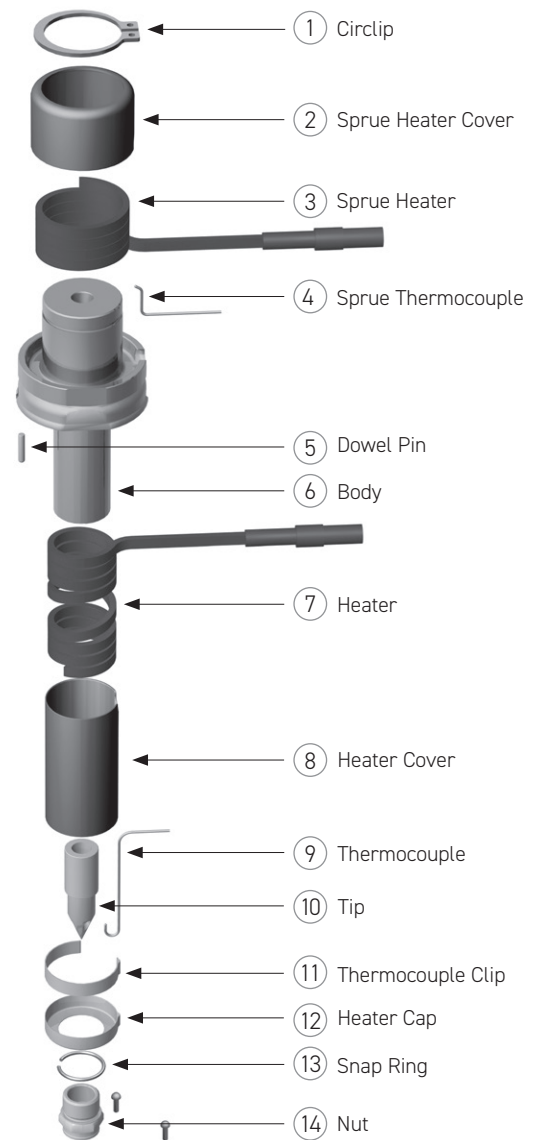

SX Nozzle Body Lengths**																					
Series	Steel	45	55	65	75	85	95	105	115	130	145	160	175	200	225	250	275	300	350	400	450
13	H13 (Std)	F1	F1	F1	F1	F1	F1	F1	F1	F1	F1	F1	F1	F1*	F1*	---	---	---	---	---	---
	420 (SS)	F3	F3*	F3*	F3*	F3*	F3*	F3*	F3*	F3*	F3*	F3*	F3*	F3*	F3*	---	---	---	---	---	---
16	H13 (Std)	F1	F1	F1	F1	F1	F1	F1	F1	F1	F1	F1	F1	F1*	F1*	F1*	---	---	---	---	---
	420 (SS)	F3	F3	F3	F3*	F3*	F3*	F3*	F3*	F3*	F3*	F3*	F3*	F3*	F3*	F3*	---	---	---	---	---
19	H13 (Std)	F1	F1	F1	F1	F1	F1	F1	F1	F1	F1	F1	F1	F1*	F1*	F1*	F1*	F1*	---	---	---
	420 (SS)	F3*	F3	F3	F3	F3*	F3*	F3*	F3*	F3*	F3*	F3*	F3*	F3*	F3*	F3*	F3*	F3*	---	---	---
27	H13 (Std)	---	---	---	F1	F1	F1	F1	F1	F1	F1	F1	F1	F1	F1	F1	F1	F1*	F1*	F1*	F1*
	420 (SS)	---	---	---	F3	F3*	F3*	F3*	F3*	F3*	F3*	F3*	F3*	F3*	F3*	F3*	F3*	F3*	F3*	F3*	F3*

* Length not stocked, available on request
 ** Custom lengths available on request
 Available in H13 and 420 steel
 To suit machine nozzle orifice and radius

SX Nozzle Series

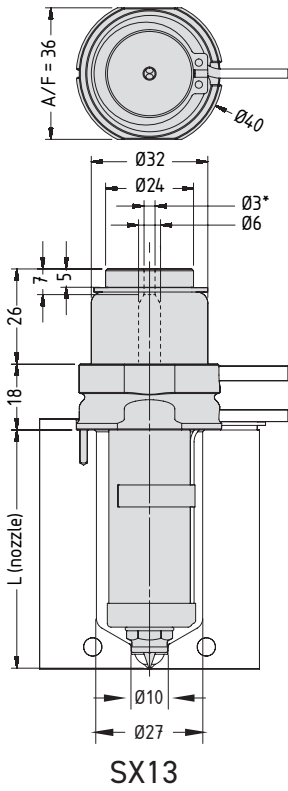

SX13

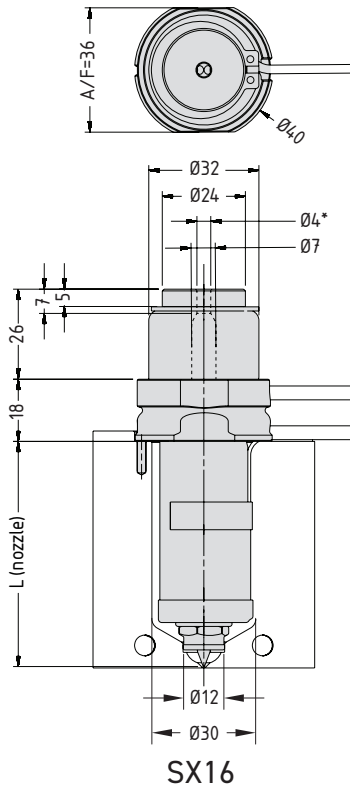

SX16

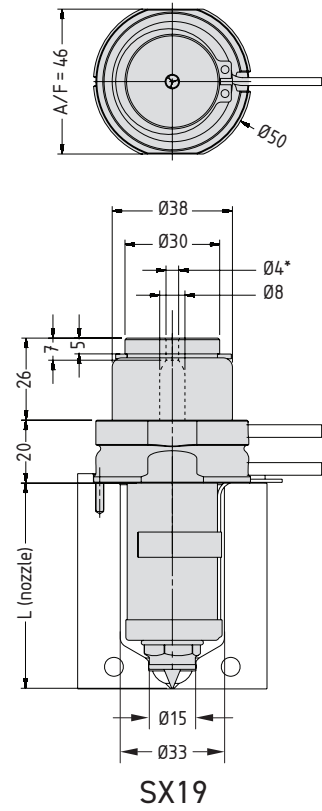

SX19

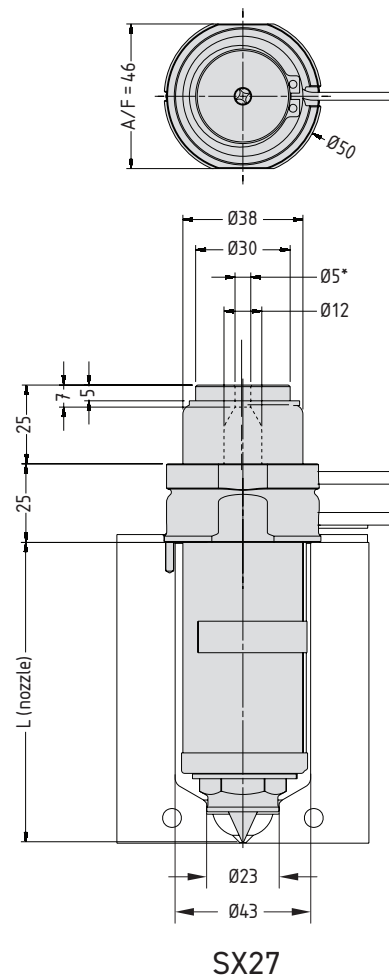

SX27

TX - FlowLoc™ Nozzle Overview

FlowLoc™ Technology Range are designed to provide a secure, leak-proof solution for multi-cavity manifold systems.

FLOWLOC™ FEATURES

Design

- Available in 16, 19 and 27 Series nozzle in a variety of lengths with the ability to order special length nozzles
- Features a threaded base to attach securely to the manifold
- Available in thermal gate
- Suitable for low to high cavity applications
- Shares the same gate profiles as existing X-Range nozzles

Operation

- Incorporates advanced heating technology with embedded heaters for exceptional thermal performance
- Threaded nozzle screws directly into the manifold providing a secure, leak-proof solution
- Capable of processing a wide range of polymers including abrasive fillers
- Excellent thermal profile along the entire length of the nozzle ensures a wide moulding window
- Suitable for high pressure applications

Installation and Maintenance

- Simple installation via threaded base
- Utilises Mastip's proven X-Range tips and nuts
- Individual components are readily available on express order from our service team

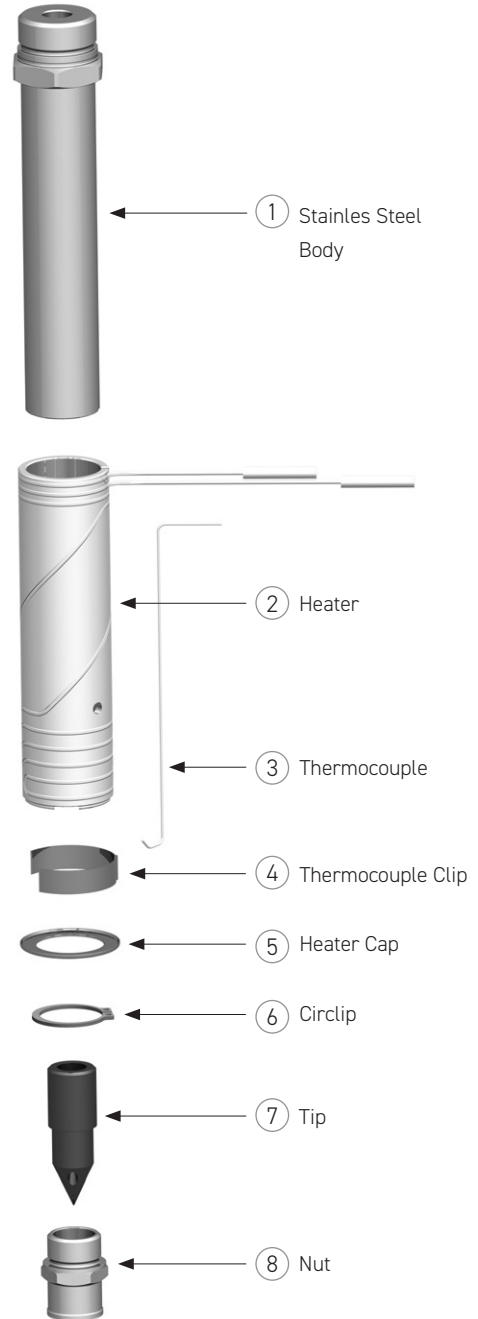

TX Nozzle Body Lengths**																		
Series	Steel	75	85	95	105	115	130	145	160	175	200	225	250	275	300	350	400	450
16	420 (SS)	F3	F3	F3	F3	F3	F3	F3	F3	F3	F3*	F3*	F3*	—	—	—	—	—
19	420 (SS)	F3	F3	F3	F3	F3	F3	F3	F3	F3	F3*	F3*	F3*	F3*	F3*	—	—	—
27	420 (SS)	F3	F3	F3	F3	F3	F3	F3	F3	F3	F3	F3	F3	F3	F3*	F3*	F3*	F3*

* Custom lengths available on request
Available in 420 steel

TX FlowLoc™ Nozzle

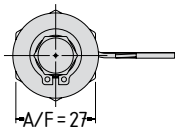
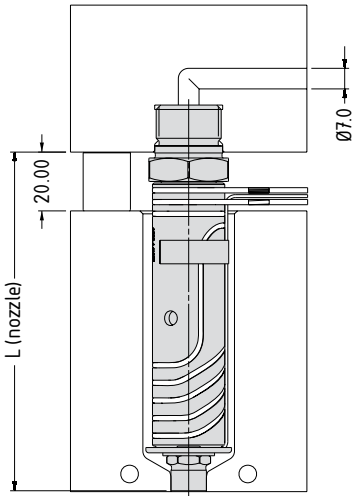

TX16075 - TX16200

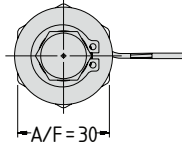
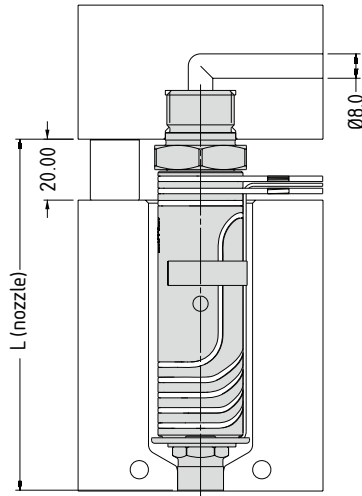

TX19075 - TX19200

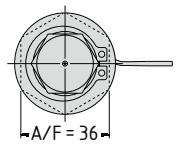
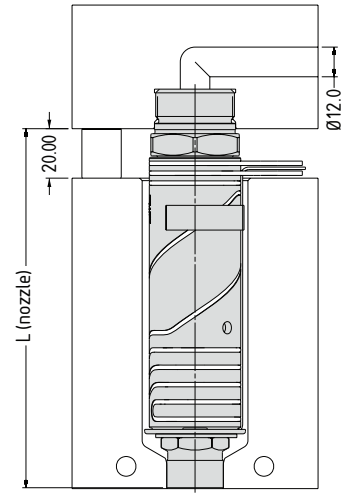

TX27075 - TX27200

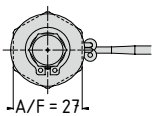
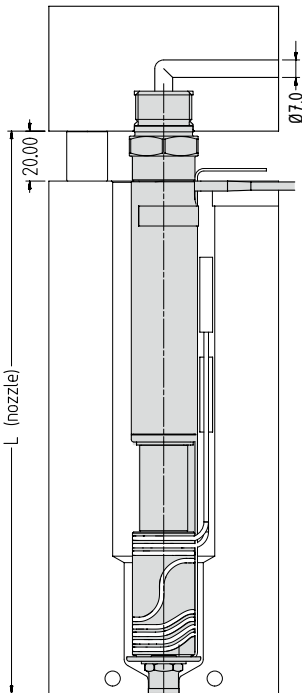

TX16225 - TX16250

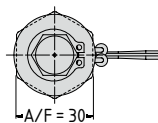
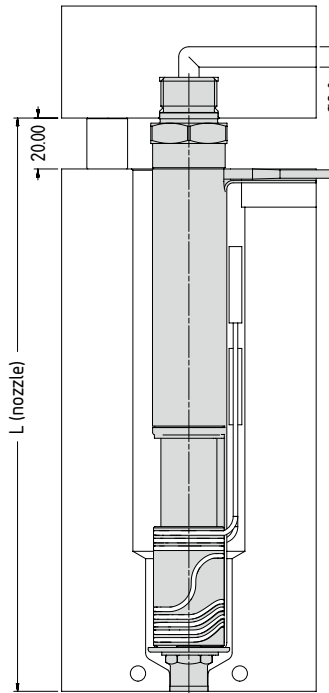

TX19225 - TX19300

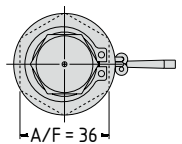
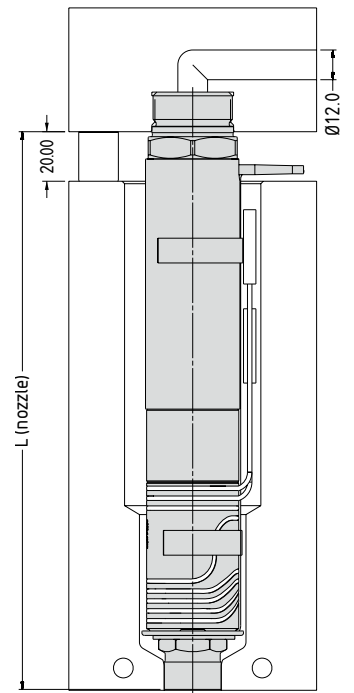

TX27225 - TX27450

VeriShot™ Single Valve Gate System

Mastip's VeriShot™ is an extremely compact, adjustable single valve gate system. The VeriShot™ incorporates advanced heating technology for exceptional thermal performance in applications requiring high cosmetic finish, high flow rates and dimensional accuracy.

VERISHOT™ FEATURES

Design

- Available to suit TX16, TX19 & TX27 series threaded nozzles
- Compact annular design
- Reduced mould height
- Multiple gate profiles to suit a broad range of applications
- VeriShot™ functions as a locating ring for mould alignment
- Locating ring supplied in metric and imperial sizes

Operation

- Advanced heating technology
- Exceptional thermal performance
- Capable of processing a wide range of polymers
- Adjustable valve pin
- Incorporates superior FlowLoc™ Technology providing a secure, leak-proof solution

Installation and Maintenance

- Simple Installation
- Utilises proven X-Range tips and nuts

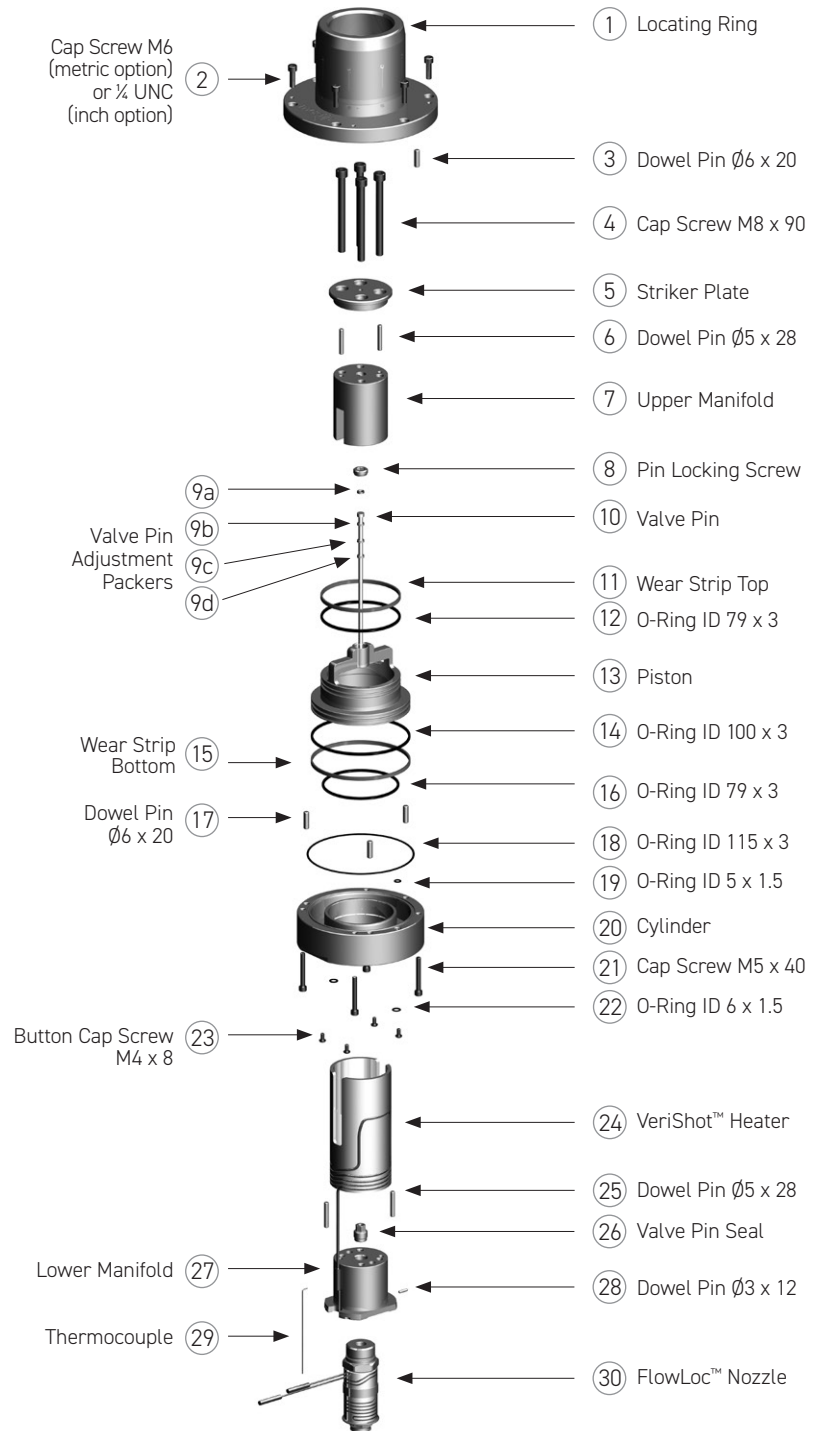

VeriShot™ Single Valve Gate System

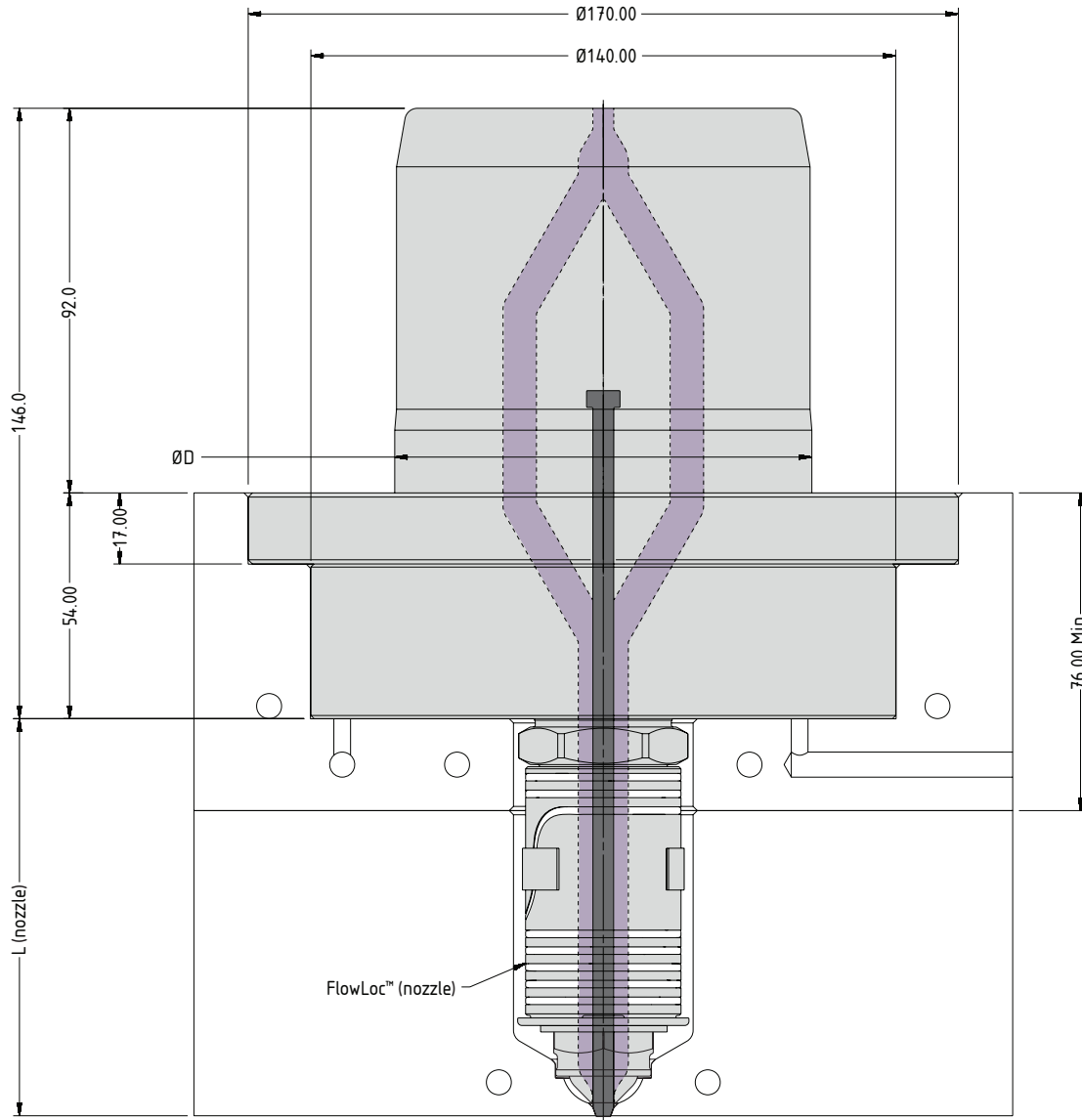

	Metric	Inch
ØD	100-125mm	4" - 5"

VeriShot™ Nozzle Compatibility			
Description	FlowLoc™ Nozzle	Supplied Pin Size	L (nozzle)
VeriShot™ 16	TX16	$\text{Ø}2.5 \times 350$	75 - 200
VeriShot™ 19	TX19	$\text{Ø}3.0 \times 400$	75 - 300
VeriShot™ 27	TX27	$\text{Ø}5.0 \times 600$	75 - 450

Note

1. Lengths can be customised to suit your requirements on request.
2. Multiple diameter locator ring sizes now come as standard to suit your requirements.

MVG25 Headed Pin Valve Gate System

MVG25 FEATURES

Mould Design

- Available to suit MX and BX Nozzles
- Standard minimal pitching is 55mm – can be modified to fit 43mm
- Backplates 50mm minimum
- Conical or Cylindrical shut off
- Easy machining of the pockets
- Pneumatic circuit integrated with the backplate

Moulding Benefits

- Reduced moulding pressure
- Increased moulding window
- Lower mould filling stress results in better part quality
- Reduced gate cooling requirements

Installation and Maintenance

- Easy machining and installation
- Easy seal replacement
- Valve pin height is adjustable
- Comes with Headed Pin design, with incremental adjustment

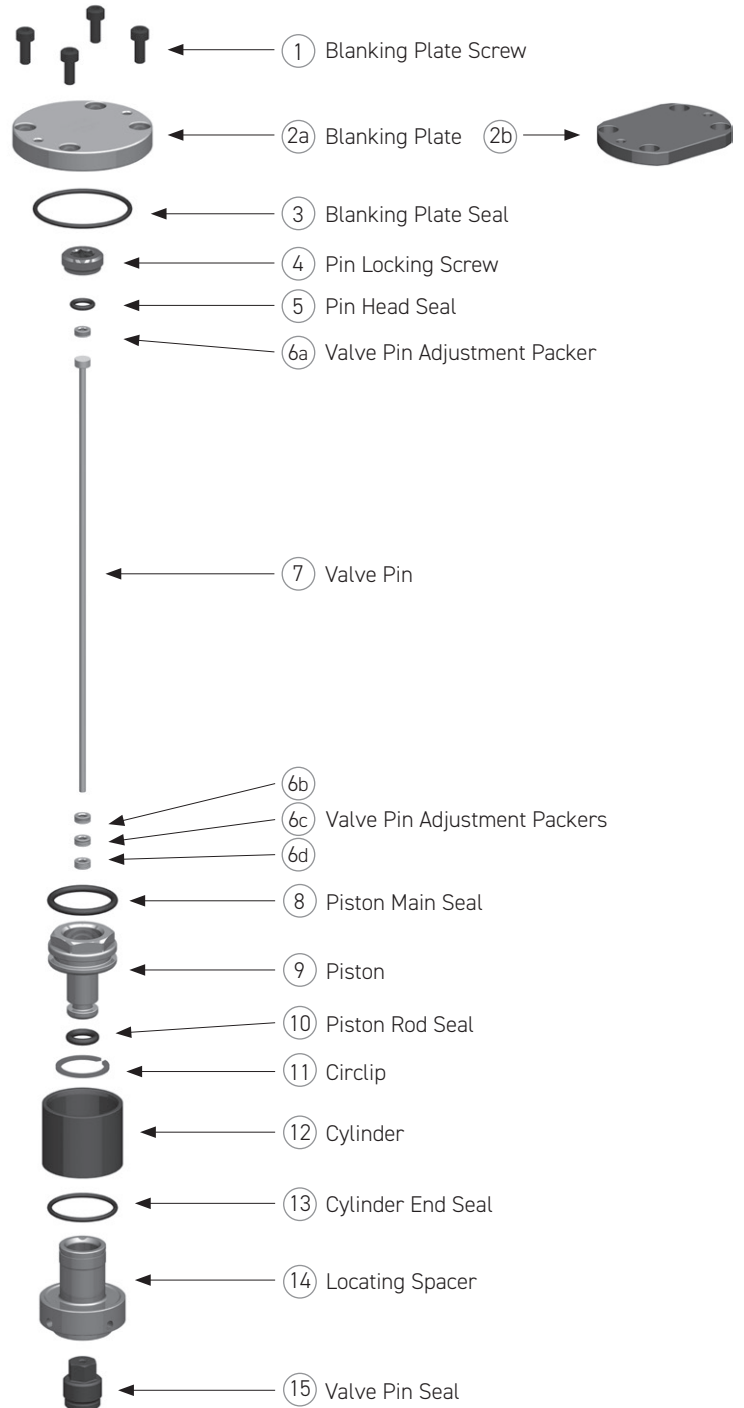

MVG25 Headed Pin Valve Gate System

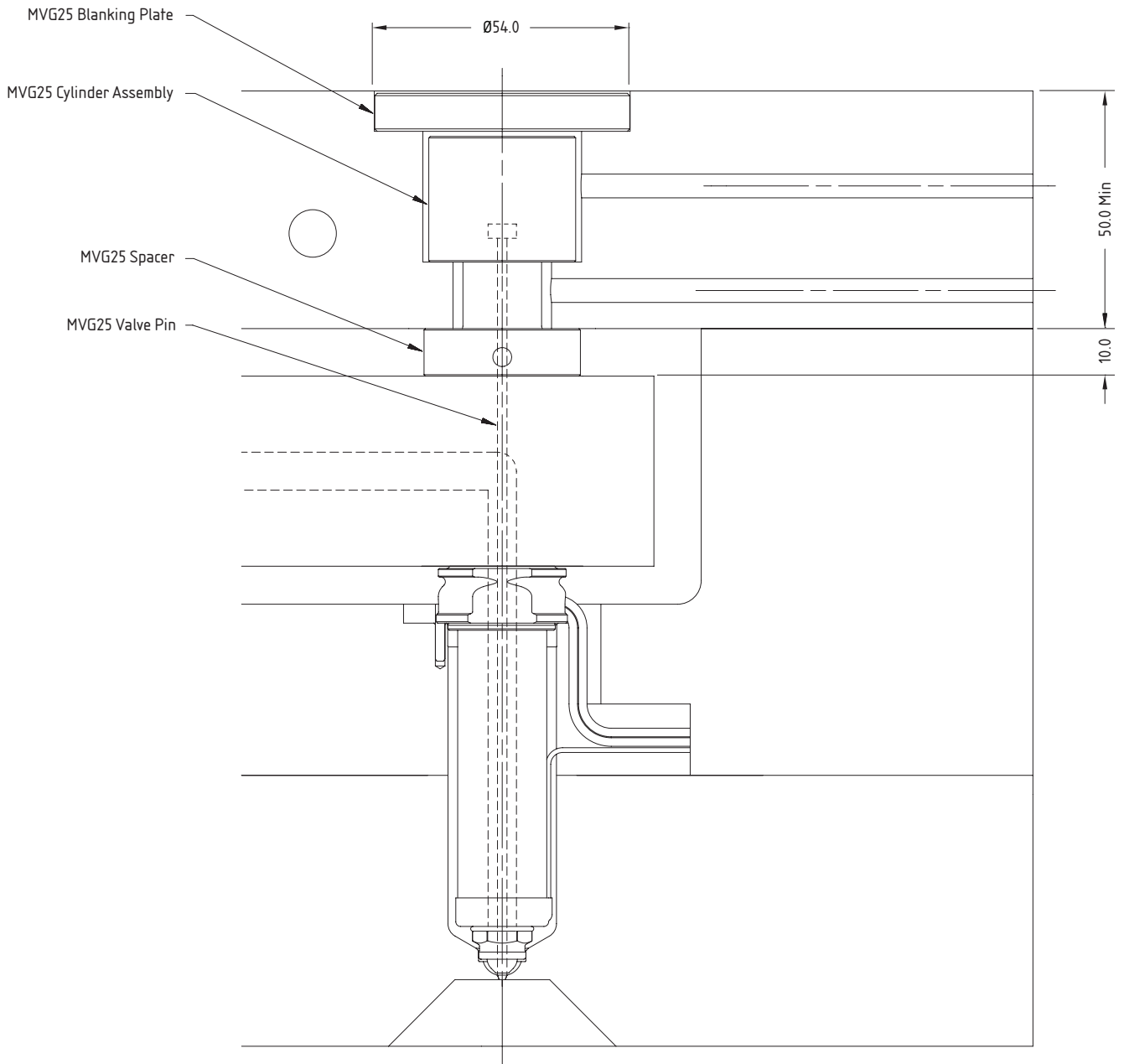

MVG25 Nozzle Compatibility			
Description	Nozzle	Nozzle Length	Supplied Pin Size
MVG25-P1 Headed Pin	MX13	45 - 175	Ø2.0
	BX13	45 - 225	
	MX16	45 - 175	Ø2.5
	BX16	45 - 250	

MVG40 Headed Pin Valve Gate System

MVG40 FEATURES

Mould Design

- Available to suit MX and BX Nozzles
- Standard minimal pitching is 75mm
- can be modified to fit 58mm pitching
- Backplates 55mm minimum
- Conical or Cylindrical shut off
- Easy machining of the pockets
- Pneumatic circuit integrated with the backplate

Moulding Benefits

- Reduced moulding pressure
- Increased moulding window
- Lower mould filling stress results in better part quality
- Reduced gate cooling requirements

Installation and Maintenance

- Easy machining and installation
- Easy seal replacement
- Valve pin height is adjustable
- Comes with Headed Pin design, with incremental adjustment

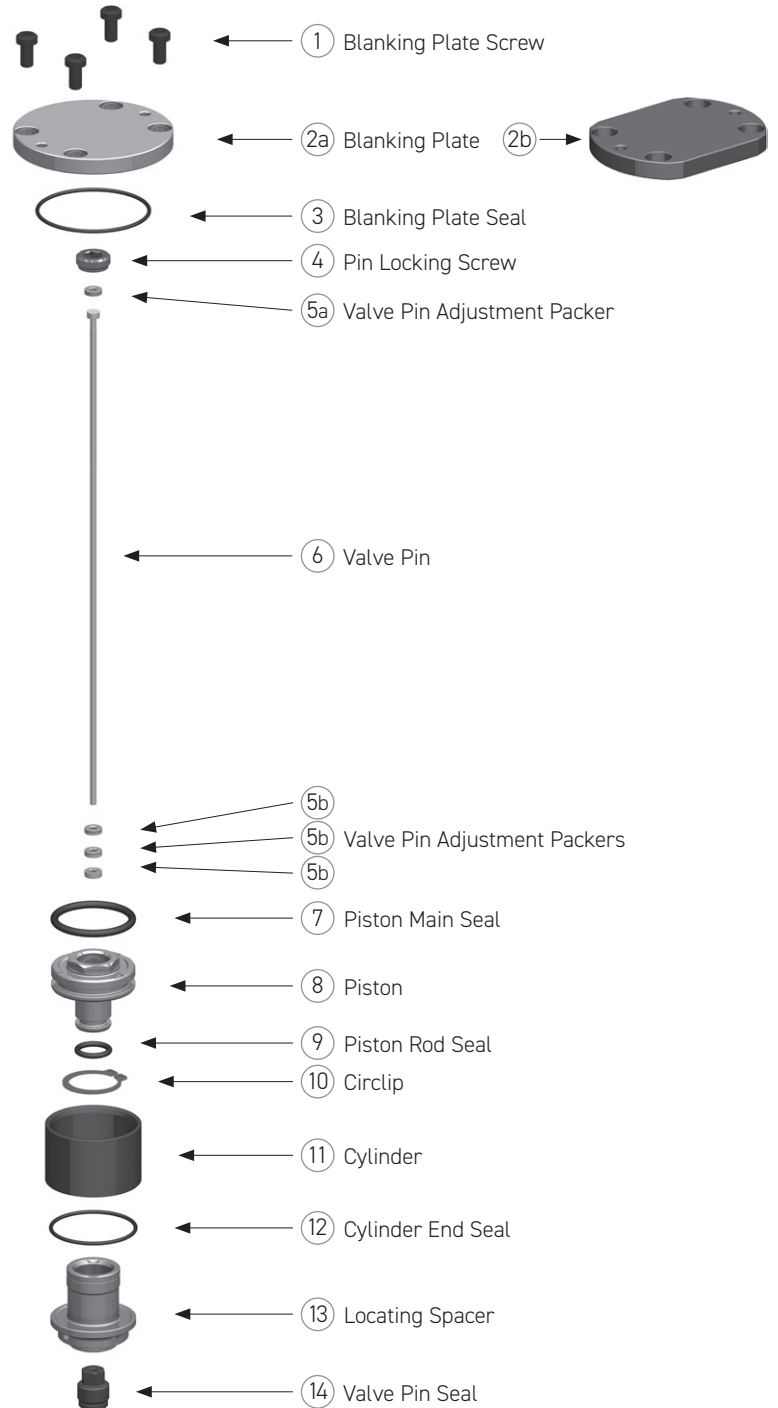

MVG40 Headed Pin Valve Gate System

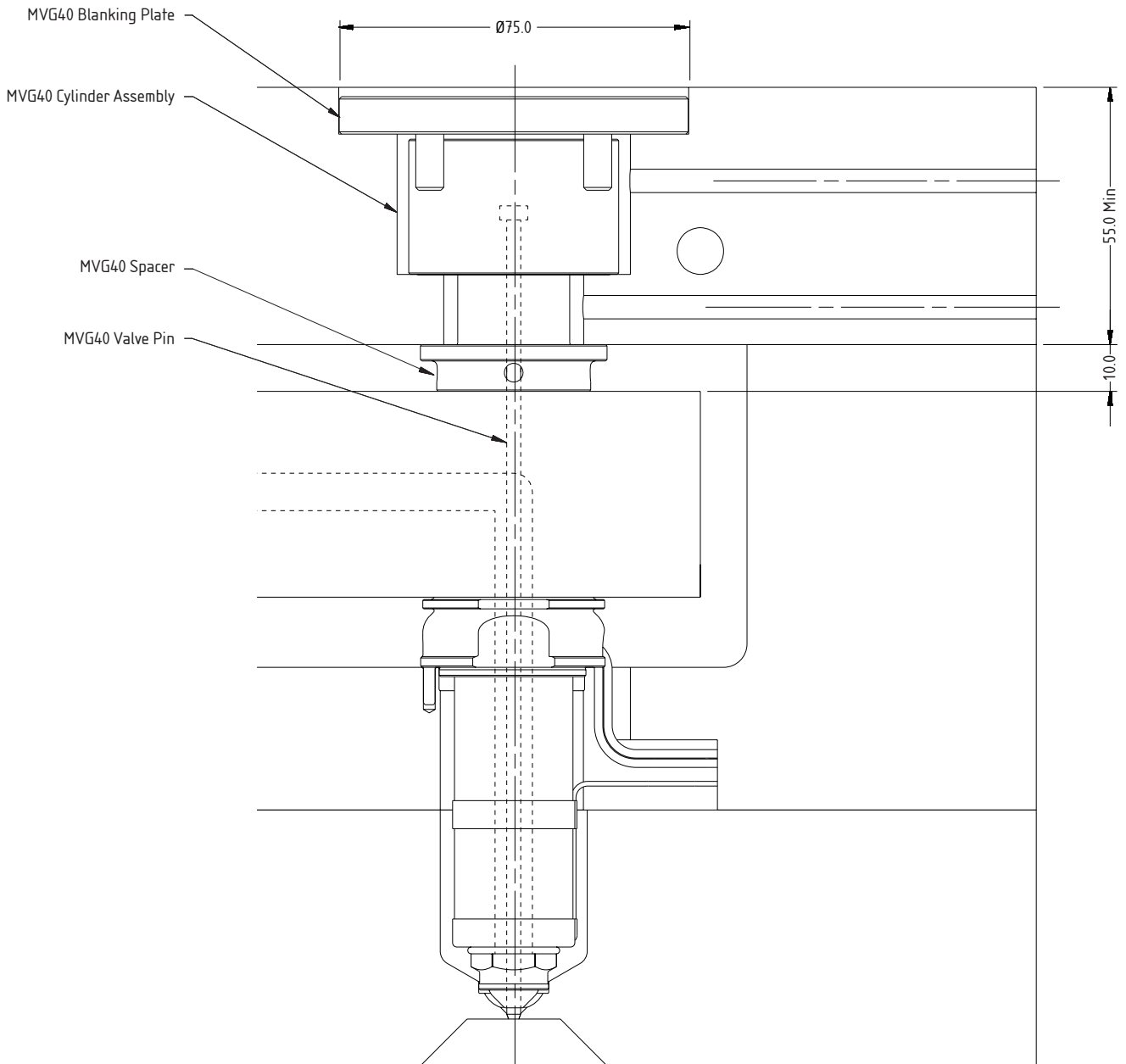

MVG40 Nozzle Compatibility			
Description	Nozzle	Nozzle Length	Supplied Pin Size
MVG40-P1 Headed Pin	MX13	45 - 175	$\varnothing 2.0$
	BX13	45 - 225	
	MX16	45 - 175	$\varnothing 2.5$
	BX16	45 - 250	
	MX19	45 - 175	$\varnothing 3.0$
	BX19	45 - 300	
	BX27	75 - 450	$\varnothing 5.0$

MVG40 Threaded Pin Valve Gate System

MVG40 FEATURES

Mould Design

- Available to suit MX and BX Nozzles
- Standard minimal pitching is 75mm
- can be modified to fit 58mm pitching
- Backplates 55mm minimum
- Conical or Cylindrical shut off
- Easy machining of the pockets
- Pneumatic circuit integrated with the backplate

Moulding Benefits

- Reduced moulding pressure
- Increased moulding window
- Lower mould filling stress results in better part quality
- Reduced gate cooling requirements

Installation and Maintenance

- Easy machining and installation
- Easy pin adjustment and seal replacement while the mould remains assembled
- Comes with Threaded Pin design fully adjustable

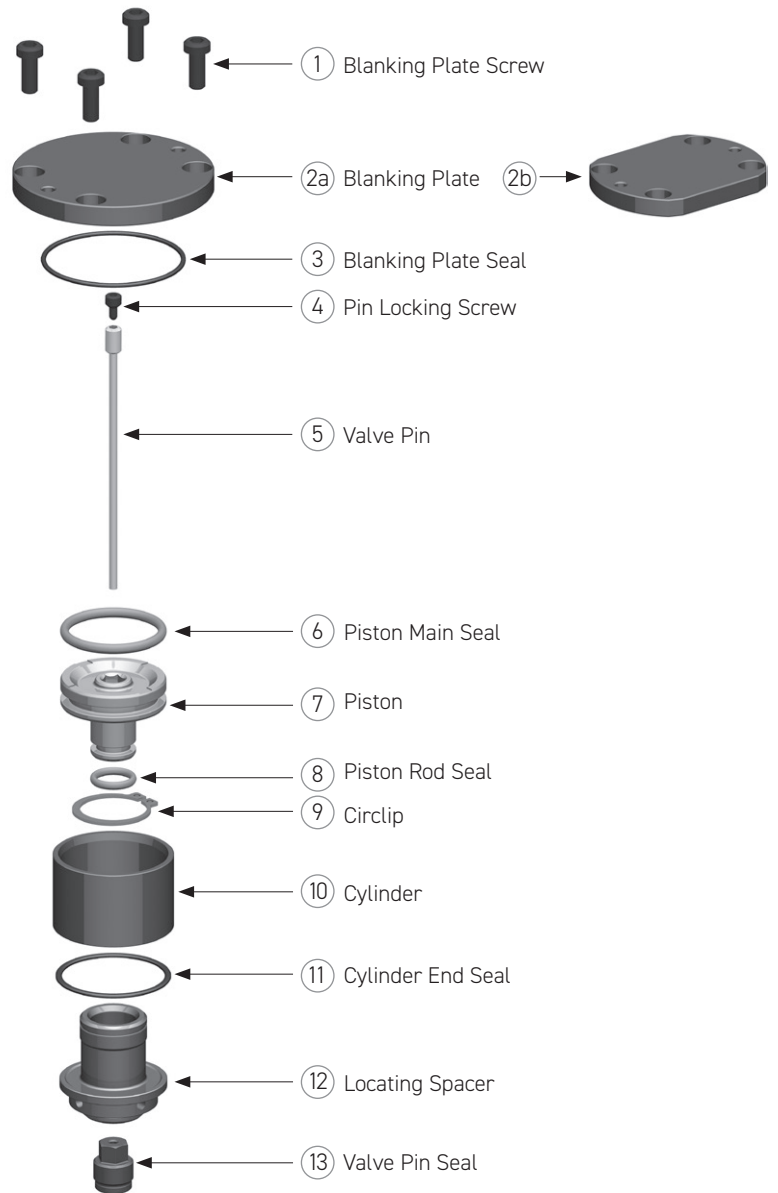

MVG40 Threaded Pin Valve Gate System

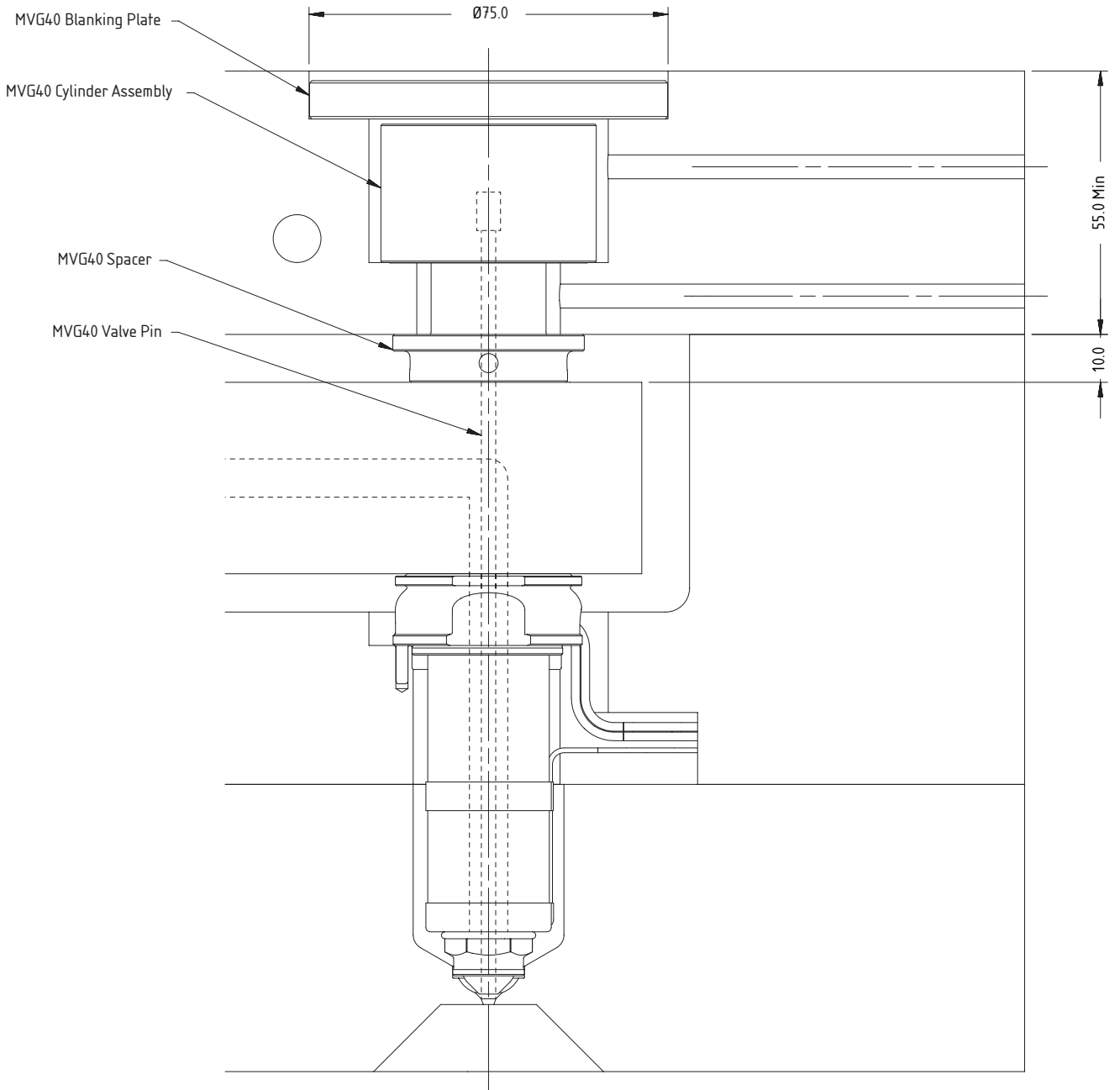

MVG40 Nozzle Compatibility			
Description	Nozzle	Nozzle Length	Supplied Pin Size
MVG40-P2 Threaded Pin	MX13	45 - 145	Ø2.0
	BX13	45 - 145	
	MX16	45 - 145	Ø2.5
	BX16	45 - 145	
	MX19	45 - 175	Ø3.0
	BX19	45 - 300	
	BX27	75 - 400	Ø5.0

MVG55 Headed Pin Valve Gate System

MVG55 FEATURES

Mould Design

- Available to suit BX Nozzle in 27 Series
- Standard minimal pitching is 95mm can be modified to fit 74mm
- Backplates 55mm minimum
- Easy machining of the pockets
- Pneumatic circuit integrated with the backplate

Moulding Benefits

- Reduced moulding pressure
- Increased moulding window
- Lower mould filling stress results in better part quality
- Reduced gate cooling requirements

Installation and Maintenance

- Easy machining and installation
- Easy seal replacement
- Valve pin height is adjustable
- Comes with Headed Pin, with incremental adjustment

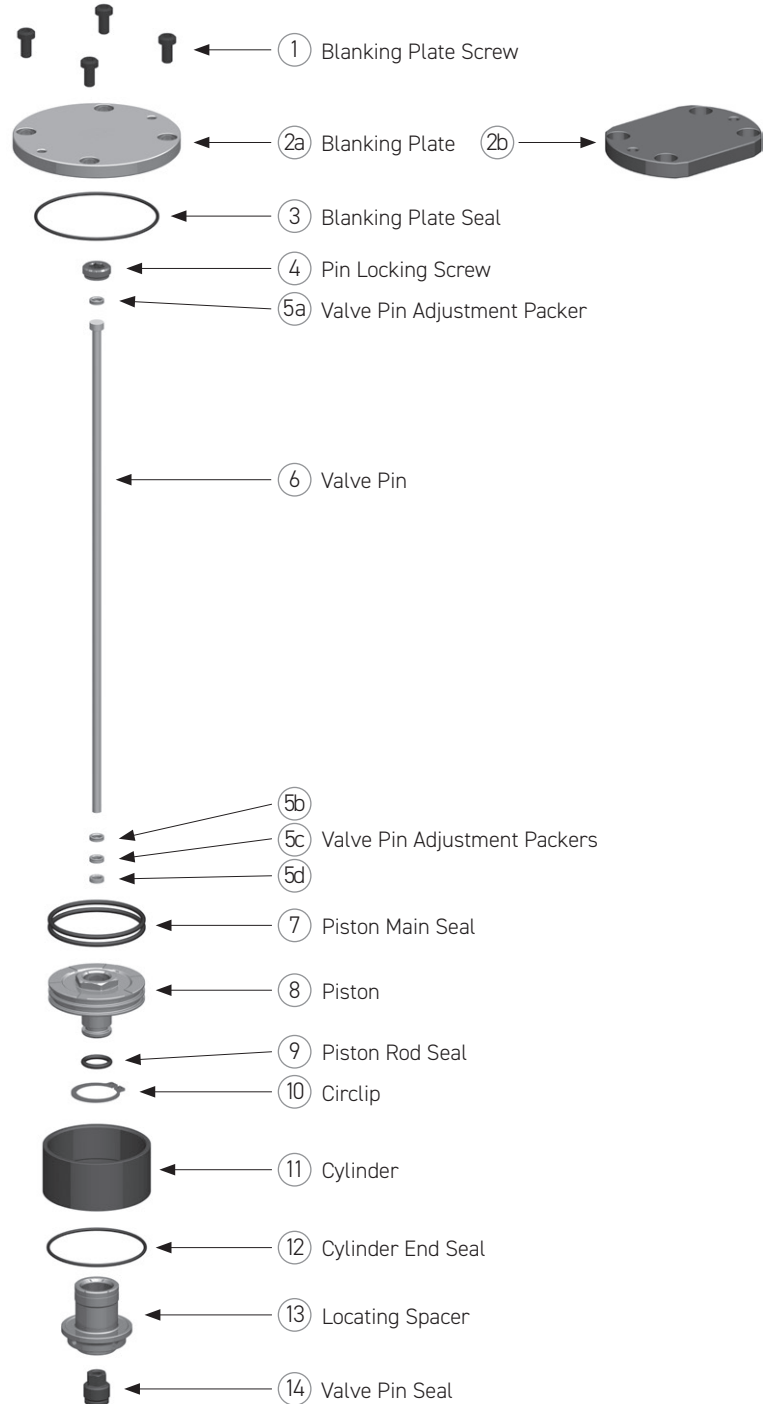

MVG55 Headed Pin Valve Gate System

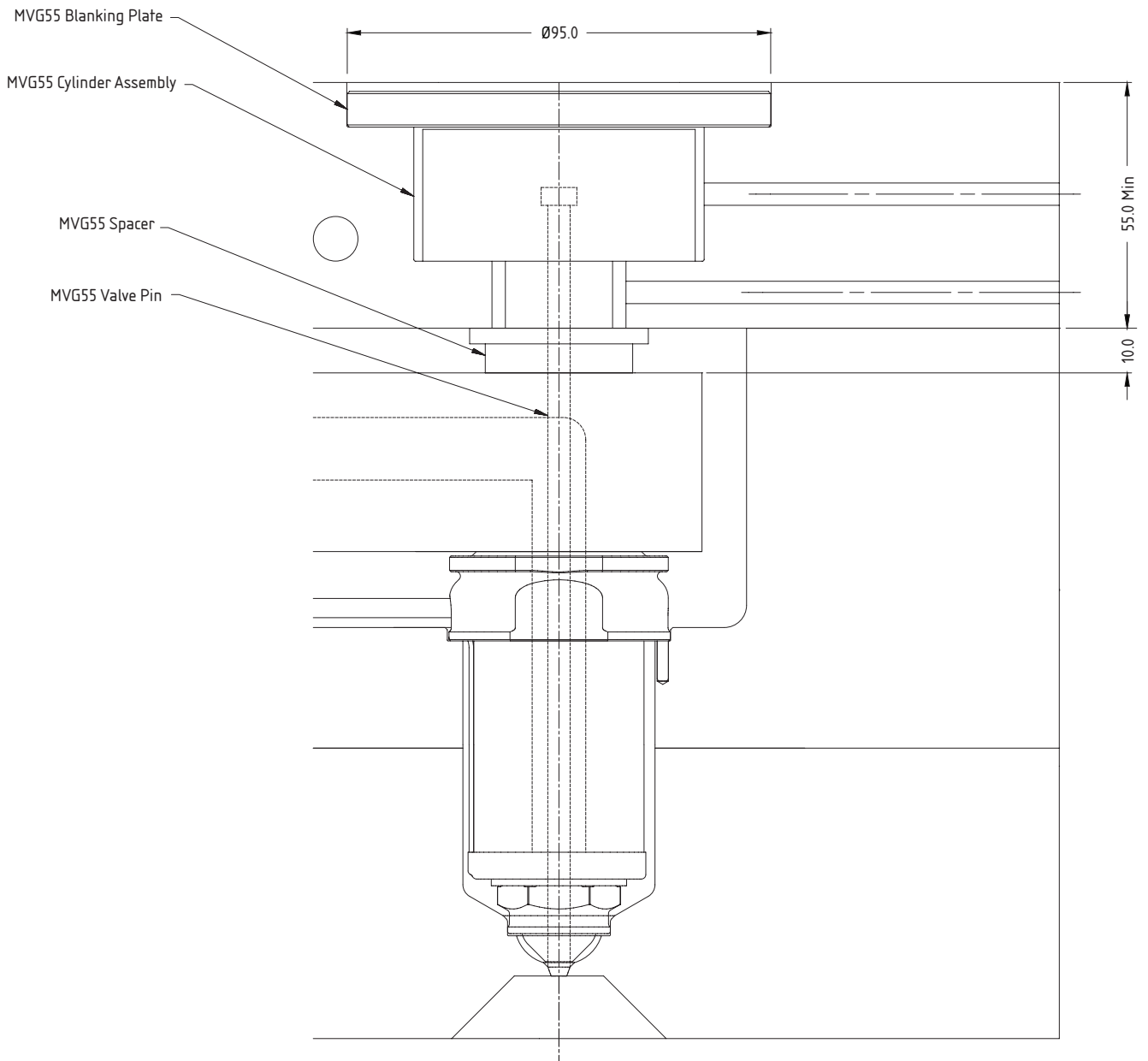

MVG55 Nozzle Compatibility			
Description	Nozzle	Nozzle Length	Supplied Pin Size
MVG55-P1 Headed Pin	BX27	75 - 450	Ø5.0

Cylix Hybrid Valve Gate System

CYLIX FEATURES

Mould Design

- Available to suit MX, BX, TX, FlowLoc™ Nozzle
- Standard minimal pitching is 60mm
- Backplates 65mm minimum
- Conical (1) or Cylindrical (2) shut off
- Easy machining of pockets

Moulding Benefits

- Reduced moulding pressure
- Wide moulding window
- Low mould filling stress results in better part quality
- Reduced gate cooling requirements

Installation and Maintenance

- Cylix pneumatic or hydraulic actuator pre-assembled to manifold
- Actuator has integrated cooling circuit to maintain integrity of seals
- PTFE/stainless braided hose
- Easy seal replacement
- Valve pin height is adjustable
- Comes with Headed Pin (P1), with incremental adjustment

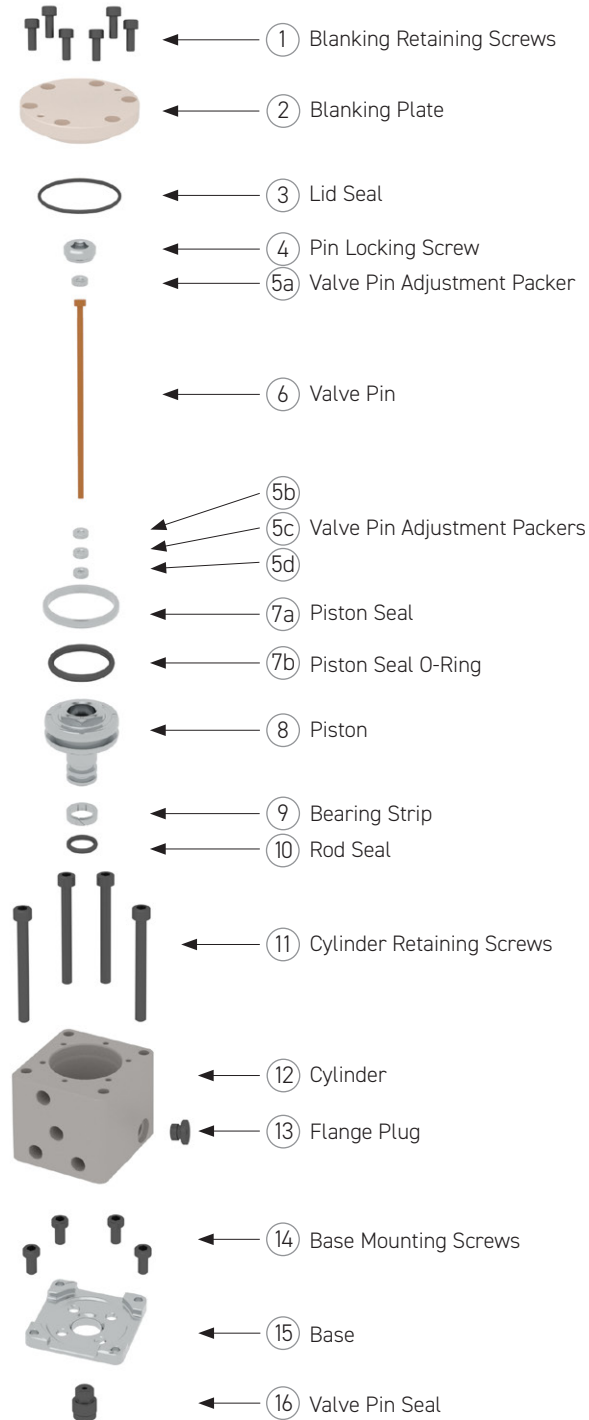

Cylix Hybrid Valve Gate System

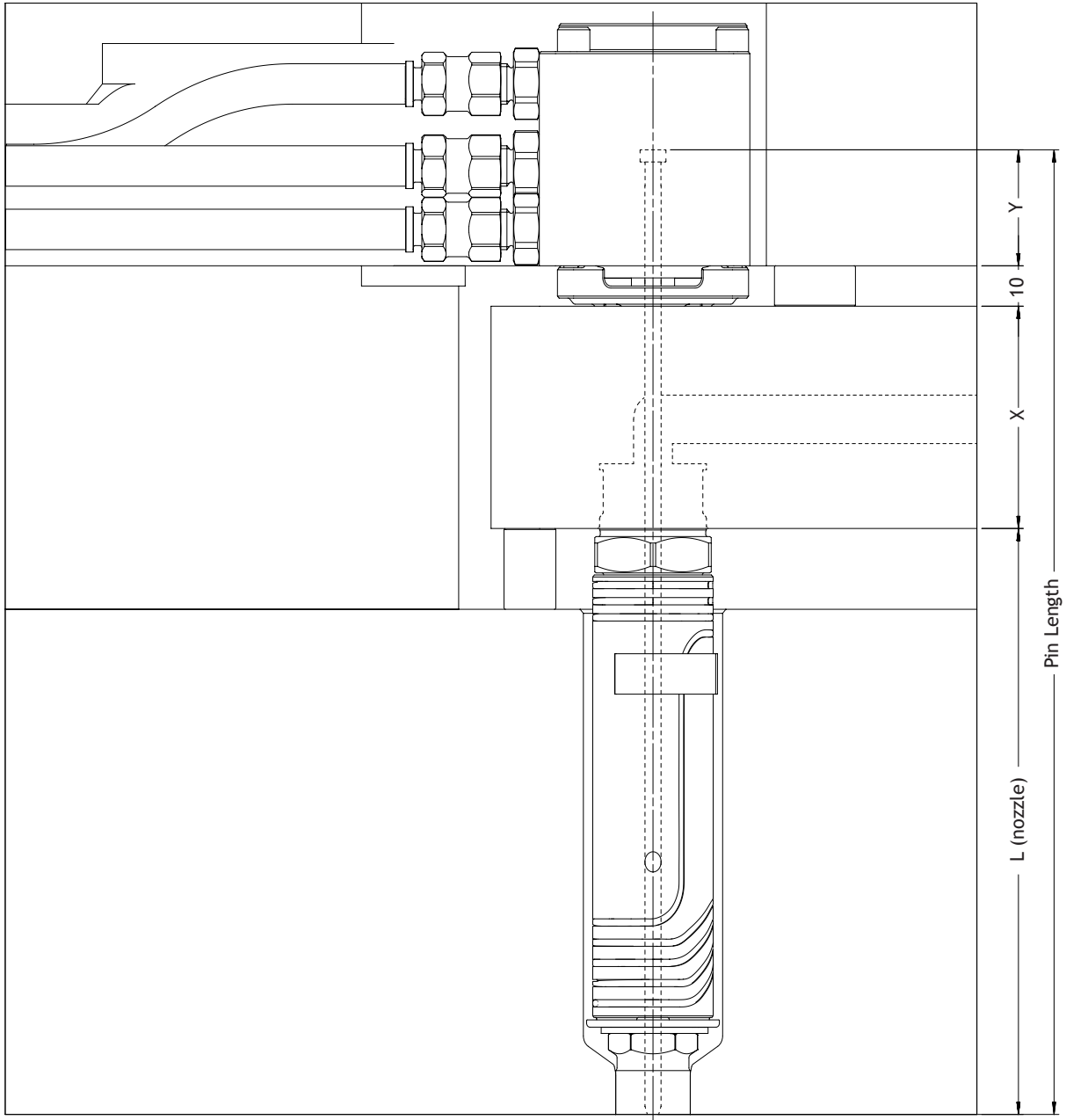

Cylix Hybrid Nozzle Compatibility			
Description	Nozzle	Nozzle Length	Supplied Pin Size
PVB40-P1 Headed Pin	MX/BX 13	45 - 225	Ø2.0
	MX/BX/TX 16	45 - 250	Ø2.5
	MX/BX/TX 19	45 - 300	Ø3.0
	BX/TX 27	75 - 450	Ø5.0

Manifold Components

Exploded view of a Standard 2 Drop Hot Runner System

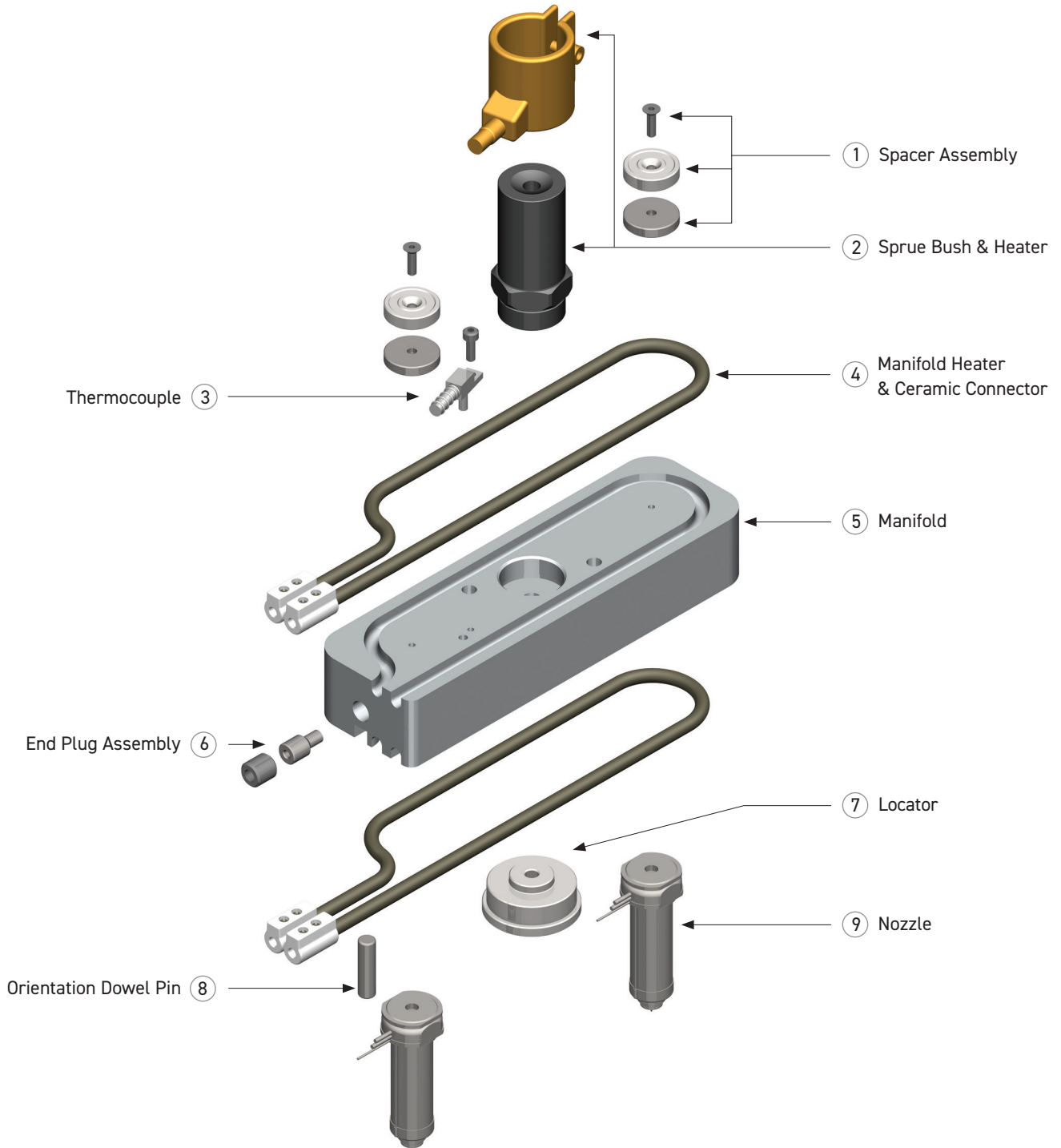

Selecting a Manifold Configuration

When deciding on a manifold layout it is important to consider the following:

- The number of injection points required per cavity
- The number of cavities in the mould
- Minimum distance between nozzles
- Balancing of the manifold
- Spacing of cavities to provide adequate room for cooling
- Gate and cavity
- Strength of the mould
- Sufficient steel between cavities
- Mould size versus machine platen size
- Total shot weight

For multi-cavity moulds balancing is critical to achieve consistent dimensions, cosmetic appearance and processing conditions across cavities. It is therefore strongly recommended that for multi-cavity moulds a manifold layout providing natural balancing is used.

Natural Balancing: In order to achieve natural balance, the material must flow through identical geometry from the machine nozzle to each of the gates.

This means identical:

- Flow distance
- Runner diameters
- Number and angle of bends

This ensures that every gate receives material in exactly the same condition. With natural balance, the balance is inherent in the design, and is not based on a specific material or processing temperature.

Rheological balancing: Is a method of balancing by using different runner sizes to artificially provide identical pressure drop at each gate. To accurately predict this, the flow properties of the material must be known, along with the flow rate and anticipated processing temperature. Any variation from the processing conditions used during design will result in an unbalanced system.

Some drop configurations can not be naturally balanced unless the drops are on a PCD and must therefore be rheologically balanced. E.g. 3, 5, 7, 9, 10, 11, 13, 14, 15, 17-23 etc

All standard Mastip manifolds (except 3 Drop 3x1) are naturally balanced.

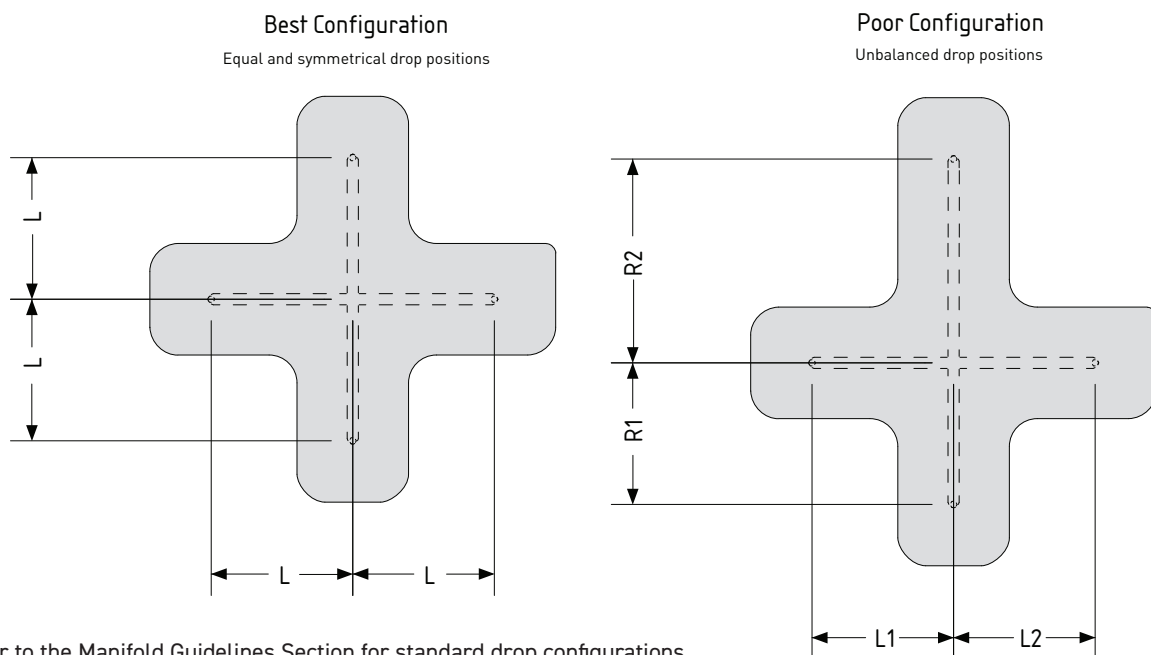

Nexus™ Systems

Mastip's Nexus™ Pre-Assembled and Pre-Wired hot runner systems are designed for fast, simple installation out of the box without requiring any further technical assembly. Nexus™ Systems incorporates superior FlowLoc™ technology providing a secure, leak-proof solution. The FlowLoc™ range ensures an excellent thermal performance using the latest heating technology.

NEXUS™ SYSTEMS

- Fully customised to suit your application requirements
- Thermal and Valve Gate configurations
- Able to process commodity and engineering grade polymers
- Fast, simple installation out of the box
- Advanced heating technology with embedded heaters
- FlowLoc™ nozzles connect securely to manifold via threaded base
- Cylix™ Valve Cylinders are available with pneumatic or hydraulic actuation and mount directly to the manifold
- Stainless steel nozzles
- Proven performance of X-Range nozzle technology
- Customised trunking for wiring
- Advanced heating technology for superior thermal performance
- Leak-proof solution via screwed in nozzles
- Accidental cold starting will not result in polymer leakage
- User-friendly maintenance
- Excellent thermal profile ensures a wide moulding window
- Unit removes easily from mould facilitating quick, easy service and maintenance

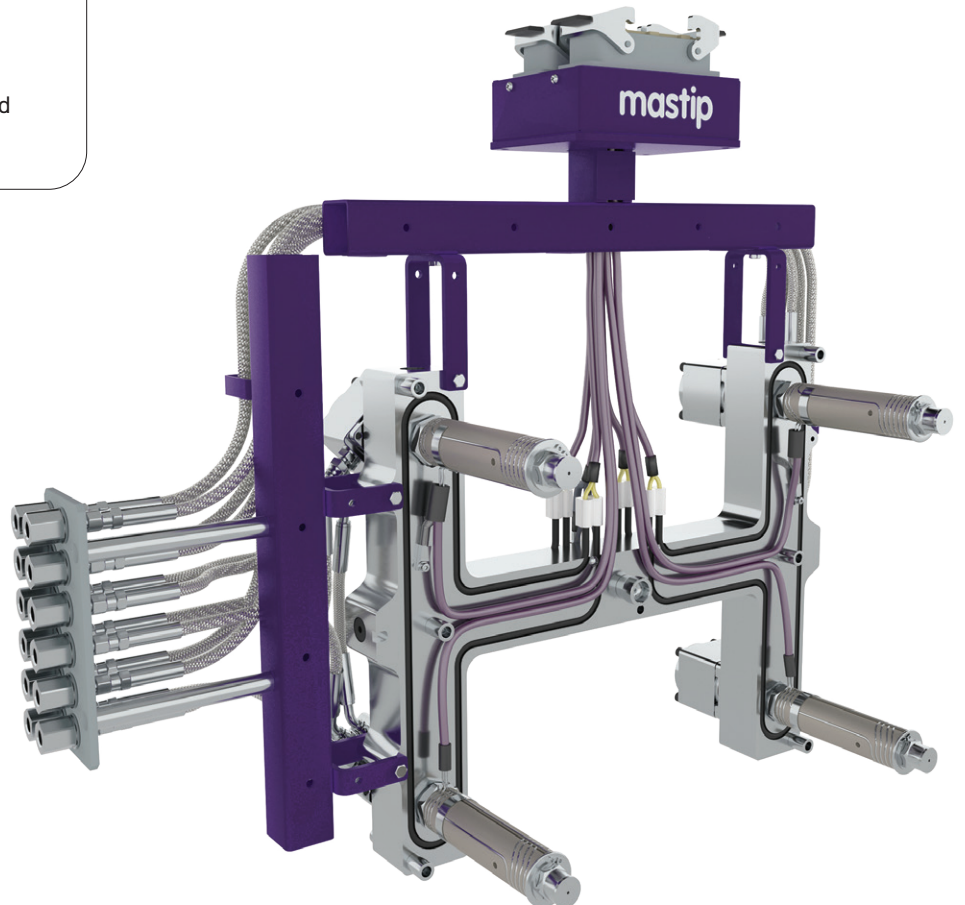

Hot Half System

All Mastip's Hot Half solutions, from low to high cavity thermal or valve gate systems, are delivered as a complete solution to integrate seamlessly with your completed mould.

HOT HALF FEATURES

Applications

- Fully customised to suit your application requirements
- Able to process commodity and engineering grade polymers

Features

- Plates available in high quality P20 steel or 420 stainless steel
- Proven performance of X-Range nozzle technology
- Delivered fully assembled and fully wired

Benefits

- Advanced heating technology for superior thermal performance
- Easy servicing of nozzles, tips, thermocouples and heaters
- Heaters are front loading
- Excellent thermal profile ensures a wide moulding window
- 3-year leak proof guarantee



Additional Considerations

To select a Hot Runner System to match your part and material specifications consideration must be given to the following:

- Gate type
- Gate size
- Nozzle range and series
- Nozzle tip style
- Nozzle nut type

Selecting Material

There are three broad categories of materials each relating to its moulding characteristics:

- Easy
- Medium
- Difficult

When selecting material consider the following:

- Materials with large percentages of filler (for example, >15%) or very low MFI, the material classification moves up a grade (for example, easy to medium).

Selecting a Gate Type

The following factors must be considered when selecting a gate type:

- Shot size of part
- Material to be moulded
- Material
- Viscosity
- Additives
- Glass fibre
- Flame retardant
- Gate surface finish
- Thickness of part walls
- Longest flow length of part
- Required cycle time

When designing an injection mould, the type, size and location of the gate is one of the most important consideration for correct moulding of the part. Incorrect gate position can result in uneven filling, over packing, and dimensional instability.

Available gate types include:

- Direct gating
- Valve gating

Direct gating is the most common gate type as it offers simple construction and reliability.

→ Refer to the Nozzle Section for more information about Gate Types

Gate Size

The correct gate size ensures a good thermal gate is achieved and minimises the pressure drop across the gate while maintaining its structural integrity. Parts with very thin wall sections or very long flow lengths need a larger nozzle and gate to achieve proper filling, this may require increasing the nozzle by one to two series.

The gate sizes effects the:

- Flow rate
- Pressure drop through the system
- Cycle time
- Thermal gate shut off after filling
- Cosmetic impact of the gate on the part
- Cooling in the gate area

The gate size is dependent on the:

- Material
- Material viscosity
- Part wall thickness
- Gate cooling*

* Gate cooling is a complex variable and consideration must also be given to cycle time, gate profile, and land length.

Gate Size Variables

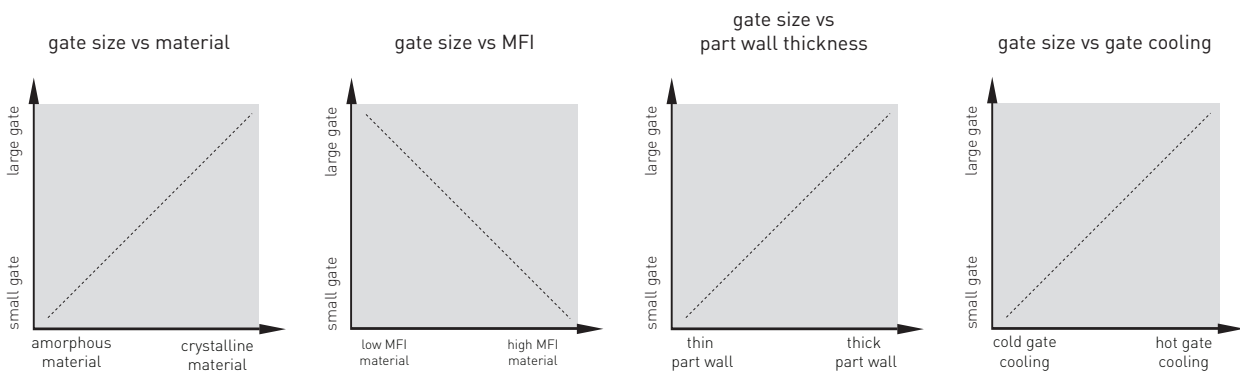

Working Example of a System Selection

To calculate the number and size of nozzles required to fill a part an initial estimate of the number of nozzles or injection points must be made. A good starting point is to limit the flow length / part thickness (L/t) ratio to the typical values for that type of material. → Refer table on page 13 - Typical Flow Length Ratios.

1 Part Details	
Description	Fluorescent Light Base
Overall Size	700 x 150 x 40 mm
Wall thickness (t)	1.5mm
Part Volume (V)	220ml

3 Hot Runner System Initial Estimates	
Number of Nozzles (N)	4
L/t	87.5 with 4 Nozzles

2 Material	
Type	ABS
Grade	Cycolac T-XS 30001
Flame retardant	Yes
Specific Gravity (SG)	1.3
L/t for wall thickness	96
Material Category	Medium - due to flame retardant move up one grade to difficult.

4 Hot Runner System Analysis Results	
Injection Pressure	93.65MPa
Injection Time (T)	1.36
Total Flow Rate (F)	$(V*SG)/T=(220*1.3)/1.36=210g/s$
Flow Rate per Nozzle	$(F/N)=210/4=52.5g/s$

Part Model - Fluorescent Light Base

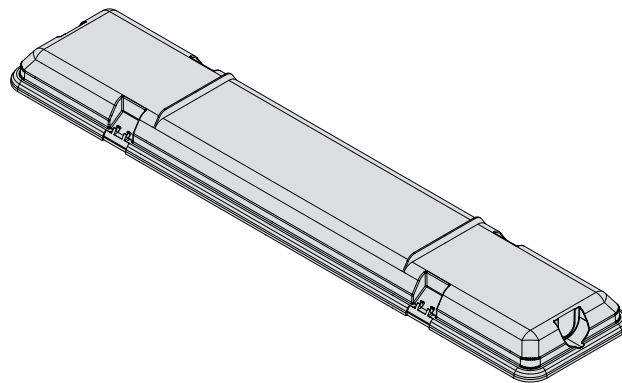

Nozzle Series Selection

19 Series Nozzle is best suited due to the required flow rate of 52.5 g/sec. and the ABS material fitting the medium to difficult material category.

Touch-Screen Temperature Control System - Meticom CTI

METICOM CTI FEATURES

Features

- Full colour LCD Touch Screen
- LCD can be fixed on mainframe or stand alone
- Max 120 zones
- Soft Start function to protect heaters during startup
- Idle mode after power failure, to protect hot runner system and mold
- Self test on startup
- CE certified
- Easy to use touch screen interface
- Mould and module diagnostics
- Quick multi-zone setup
- Power usage display
- Synchronous heating and cooling
- Automatic heater and thermocouple detection and monitoring

MetiCom CTI-300

MetiCom CTI-200



MetiCom CTI-100

MetiCom CTI-40

Technical Specifications

Model	CTI-40	CTI-100	CTI-200	CTI-300
User Interface	Full colour LCD Touch Screen			
Display Size	7.0"	7.0"/10.2"	10.2"	
Max. Total Zones	12	32	80	120
Max. Temp Zones	12	32	80	120
Max. Sequential Zones	24			
Power Supply	3-Ph+E(4 wire) 200-240Vac			
	3-Ph+N+E(5 wire) 380-415Vac			
Working Conditions	0~55 (32~131), 10~80%RH (No condensing)			
Storage Conditions	-20~70 (-4~158), 10~80%RH (No condensing)			
Temperature Range	0°C~500°C (32°F~932°F)			
Load Capacity	Rated 240Vac, 15A/zone			
Thermocouple	J or K-Type, software selectable			
Control Mode	Auto-PID / Manual			

Modular Temperature Control System - MetiCom CM

MetiCom CM Modular Controller



METICOM CM FEATURES

- Blown Fuse
- Display function of current and output ratio
- Smart SOFT START function
- Auto/Manual Selection function
- PID Automatic Temperature Control
- Output percentage limit setting
- LCD display module
- One-key start (stop)/standby (boost) function
- Built-in alert alarm
- CE Certified
- Over-voltage protection
- Heater short-circuit protection
- Automatic detection of wire breakage of heater
- TRIAC short-circuit protection
- Detection for reverse troubleshooting sensor wiring temperatures



TM10



TM20

Technical Specifications		
Modules	MetiCom TM10	MetiCom TM20
User Interface	LED Display	LCD Display
Sensor Type	J or K thermocouple	
Setting range	0°C ~450°C (32°F ~842°F)	
Measurement accuracy	±0.25%F.S.	
Control Mode	Auto PID or Manual	
Control Accuracy	±0.25%F.S	
Load Capability	15A, 50W~1650W(110V) 100W~3600W(240V)	
Operating temperature	0°C~55°C (32°F~131°F)	
Operating humidity	10~80%, non-condensing	
Storage temperature	-20°C~70°C (-4°F~158°F)	

Integrated Temperature Control System - MetiCom CIS

METICOM CIS FEATURES

- Sensor type can be changed by shortcuts
- Over-voltage protection
- Reverse of sensor and heater protection
- Fuse blowout alarm
- Triac breakdown alarm
- Overload alarm
- Thermocouple open alarm
- Thermocouple reverse alarm
- Temperature high alarm
- Temperature low alarm
- Heater fault alarm

MetiCom CIS-1



MetiCom CIS-2



Technical Specifications

Controller	MetiCom CIS-1	MetiCom CIS-2
User Interface	3-digit red LED (PV)	4-digit green LED (SV)
Sensor Type	J or K thermocouple	
Setting range	0°C ~450°C (32°F ~842°F)	
Measurement accuracy	±0.1%F.S.	
Control Mode	Auto PID or Manual	
Control Accuracy	±0.1%F.S.	
Load Capability	10A /15A per zone, 240Vac	
Operating temperature	0°C~55°C (32°F~131°F)	
Operating humidity	10~80%, non-condensing	

Sequential Temperature Control System - MetiCom SC2 / SC8

METICOM SC2/SC8 FEATURES

- Regulation of the injection quantity from each individual gate
- Quality of the moulded part can be improved by removing or repositioning of weld lines
- Injection is performed with minimum clamping force due to the gates not all opening simultaneously
- Optimum control over part fill
- Easy to setup and simple to operate

MetiCom SC2



MetiCom SC8



Technical Specifications		
Controller	MetiCom SC2	MetiCom SC8
Display	7.0" Colour Touch Screen	LED Display
Operating Modes	Mode A, Mode B, Mode C	Mode A, Mode B, Mode AB
Operating temperature range	-10 °C to 50 °C	0 °C to 55 °C
Power Requirements	AC85~265V, 50/60Hz	
Mains input power	Single phase AC 220V (50/60 Hz)	
Injection signal input power supply	DC24V/AC220V	
Solenoid output power supply	Signal voltage, 100mA/Zone	



Mastip Head Office New Zealand

558 Rosebank Road, Avondale
Auckland 1026, New Zealand

Phone: +64 9 970 2100
Email: mastip@mastip.com

Mastip Regional Office Europe

Phone: +33 0 809 400 076
Email: mastip@mastip.eu

Mastip Regional Office North America

Phone: +1 262 644 9400
Email: northamerica@mastip.com

Mastip Regional Office China

Phone: +86 755 84193188
Email: china@mastip.com

Mastip Regional Office Vietnam

Phone: +84 93 8877488
Email: quang.pham@mastip.com

For a full list of Distributors,
please visit www.mastip.com